



BATTERY FOR INDUSTRIAL AND
TELECOM APPLICATIONS





About Us

Our parent company Newstar Investments Limited was incorporated in the year 2000, when we started exporting engineering equipment and lighting systems from New Zealand to the Middle East. Over the past 15 years we have successfully completed many projects in varied sectors such as Commercial Lighting, Solar Power, Telecom Power and infrastructure. We also manufacture and supply various types of Batteries, Telecom power & infrastructure, Industrial and Solar Power Systems for our customers globally. Our strength remains in providing customized solutions, which are made to suit the customer needs and project requirements.

Our Mission

To become a supplier of choice for our customer in all sectors of our business. To provide high quality products at competitive prices to the customers. To provide excellent after sales service and correct technical advice to our customers.

Our Vision

To serve our customers not only today but well into the future. To be amiable, efficient and economical in order to maintain a lifetime relationship with our customers. To achieve constant improvement in our technical specifications and customer services.

Enlight understands customer needs in keeping abreast of new developments and systems in the Telecom / Industrial power systems and energy storage domain we are equipped to provide service to all customers locally and globally.

EVT Series For Telecom Application



Typical Applications

- Telecom system
- UPS system
- Power supply system
- Broadcast and television system
- Reserve power system
- Traffic signal system
- Emergency light system

Features

- Float charge design life for 2V is 15 years, 6v and 12v 10 years
- Low self-discharge
- Good deep discharge recovery performance
- High strength ABS material case and cover
- AGM sealed valve-regulated
- Flat plate technology
- Safe and reliable explosion-proof vented system



| Item | Model | Rated Voltage (V) | Rated Capacity (Ah) | | | Dimension | | | Weight (KG) |
|------|-----------|------------------------|-----------------------|----------------|----------------|-----------|------|-------|------------------|
| | | | C ₁₀ | C ₃ | C ₁ | L mm | W mm | TH mm | |
| 1 | EVT-200 | 2 | 200 | 150 | 110 | 88 | 177 | 377 | 13.0 |
| 2 | EVT-300 | 2 | 300 | 225 | 165 | 118 | 177 | 377 | 18.0 |
| 3 | EVT-400 | 2 | 400 | 300 | 220 | 148 | 177 | 377 | 23.0 |
| 4 | EVT-500 | 2 | 500 | 375 | 275 | 187 | 177 | 377 | 29.0 |
| 5 | EVT-600 | 2 | 600 | 450 | 330 | 218 | 178 | 377 | 35.0 |
| 6 | EVT-650 | 2 | 650 | 487.5 | 357.5 | 175 | 212 | 455 | 40.0 |
| 7 | EVT-800 | 2 | 800 | 600 | 440 | 212 | 212 | 455 | 50.0 |
| | | | | | | 290 | 180 | 378 | 46.0 |
| 8 | EVT-1000 | 2 | 1000 | 750 | 550 | 256 | 212 | 455 | 61.0 |
| | | | | | | 368 | 180 | 378 | 57.0 |
| 9 | EVT-1500 | 2 | 1500 | 1125 | 825 | 275 | 210 | 687 | 95.0 |
| 10 | EVT-2000 | 2 | 2000 | 1500 | 1100 | 367 | 214 | 687 | 129.0 |
| 11 | EVT-3000 | 2 | 3000 | 2250 | 1650 | 542 | 212 | 687 | 189.0 |
| 12 | 3-EVT-200 | 6 | 200 | 150 | 110 | 250 | 125 | 366 | 34.5 |
| 13 | 6-EVT-38 | 12 | 38 | 29 | 21 | 197 | 166 | 168.5 | 13.0 |
| 14 | 6-EVT-65 | 12 | 65 | 49 | 36 | 324 | 168 | 175 | 21.0 |
| 15 | 6-EVT-100 | 12 | 100 | 75 | 55 | 408 | 175 | 221 | 32.5 |
| 16 | 6-EVT-120 | 12 | 120 | 90 | 66 | 408 | 175 | 221 | 35.0 |
| 17 | 6-EVT-150 | 12 | 150 | 113 | 83 | 549 | 204 | 233 | 49.0 |
| 18 | 6-EVT-200 | 12 | 200 | 150 | 110 | 549 | 259 | 233 | 63.0 |

EVT Series For Telecom Application



Performance Characteristics

Temperature Effects In Relation To Float Charge Voltage

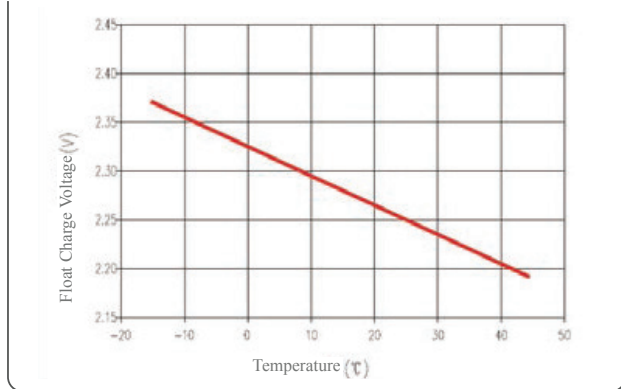

Effect Of Temperature On Float Charge Life

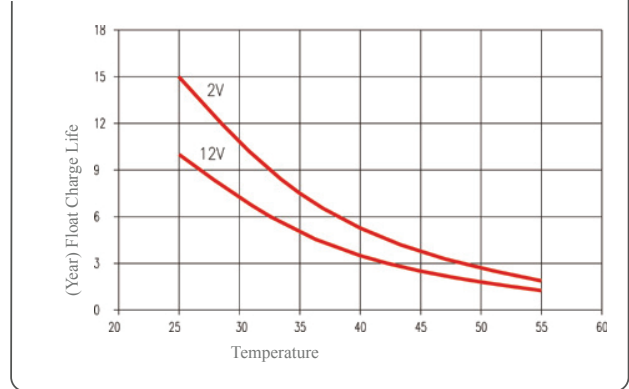

Self Discharge Characteristics

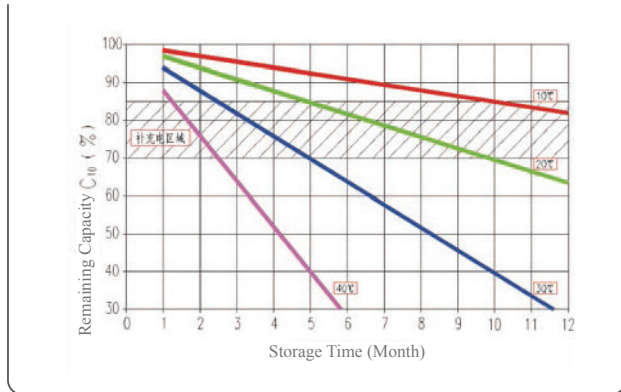

Temperature Effects In Relation To Capacity

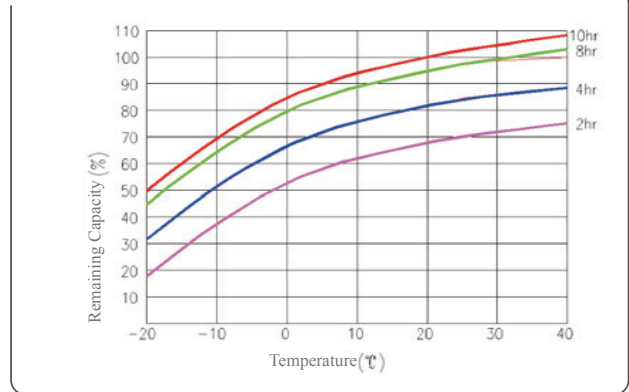

Constant Voltage Charge Characteristics

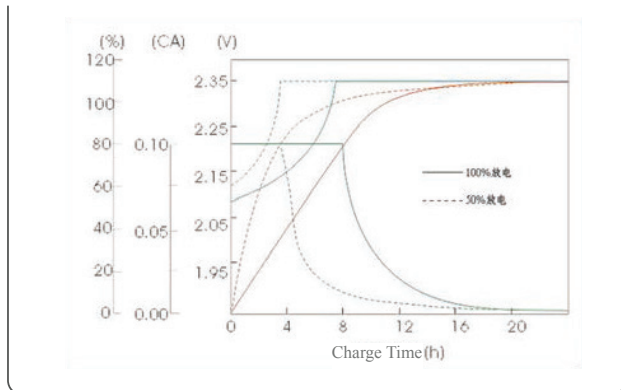

Discharge Characteristics

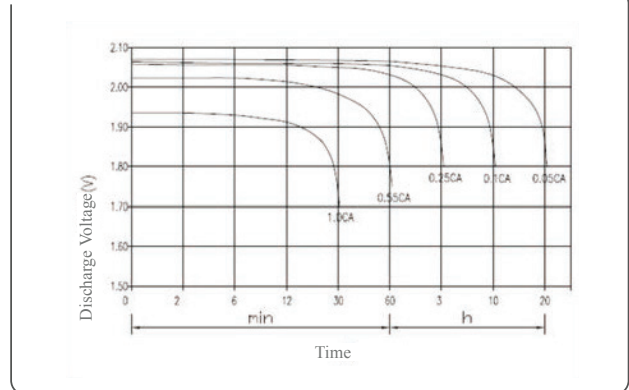

For trade enquiries please contact:

M/s Newstar Investments Limited

Post Box 27-300, Mount Roskill, Auckland 1440, New Zealand | Telephone +649 801 0976 | Email – sales@enlight.co.nz | website: www.enlight.co.nz

EVF Front Terminal Series



Typical Applications

- Telecom system
- UPS system
- Power supply system
- Broadcast and television system
- Reserve power system
- Traffic signal system
- Emergency light system

Features

- Float charge design life is 12 years
- Low self-discharge
- Good deep discharge recovery performance
- High strength ABS material case and cover
- AGM sealed valve-regulated
- Flat plate technology
- Front terminal design with good heat emission performance and make the installation, maintenance and supervision easy
- Patented vent structure
- Safe and reliable explosion-proof vented system
- Specifically ideal for 19 inch or 23 inch power cabinets
- Special handle design, convenient for carry and installation



| Item | Model | Rated Voltage (V) | Rated Capacity (Ah) | | | Dimension | | | Weight (KG) |
|------|------------|---------------------|-----------------------|----------------|----------------|-----------|------|-------|---------------|
| | | | C ₁₀ | C ₃ | C ₁ | L mm | W mm | TH mm | |
| 1 | 6-EVF-40 | 12 | 40 | 30 | 22 | 274 | 105 | 220 | 13.0 |
| 2 | 6-EVF-50 | 12 | 50 | 37.5 | 27.5 | 390 | 107 | 200 | 18.5 |
| 3 | 6-EVF-92 | 12 | 92 | 69 | 50.6 | 396 | 111 | 285 | 29.5 |
| 4 | 6-EVF-100B | 12 | 100 | 75 | 55 | 396 | 111 | 285 | 31.0 |
| 5 | 6-EVF-100A | 12 | 100 | 75 | 55 | 520 | 107 | 263 | 33.0 |
| 6 | 6-EVF-120 | 12 | 120 | 90 | 66 | 520 | 107 | 263 | 39.5 |
| 7 | 6-EVF-150 | 12 | 150 | 112.5 | 82.5 | 558 | 125 | 283 | 48.0 |
| 8 | 6-EVF-150B | 12 | 150 | 112.5 | 82.5 | 549 | 110 | 286 | 44.0 |
| 9 | 6-EVF-165 | 12 | 165 | 123.75 | 90.75 | 528 | 125 | 318 | 53.0 |
| 10 | 6-EVF-200 | 12 | 200 | 150 | 110 | 550 | 125 | 330 | 62.0 |

EVF Front Terminal Series



Performance Characteristics

Temperature Effects In Relation To Float Charge Voltage

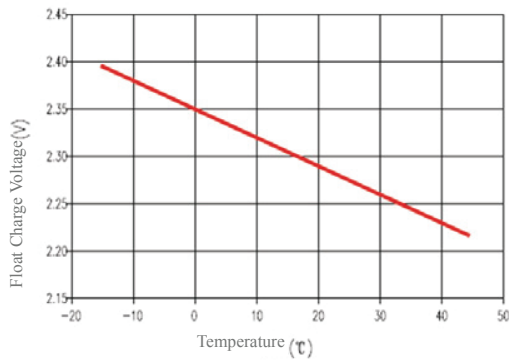

Effect Of Temperature On Float Charge Life

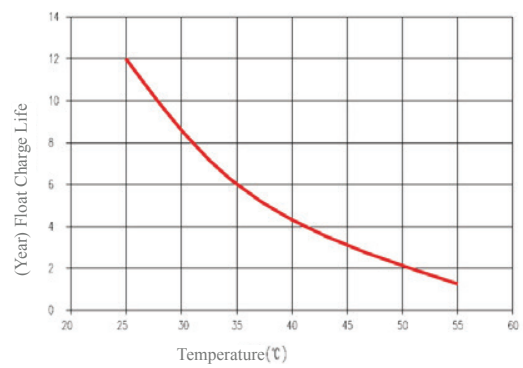

Self Discharge Characteristics

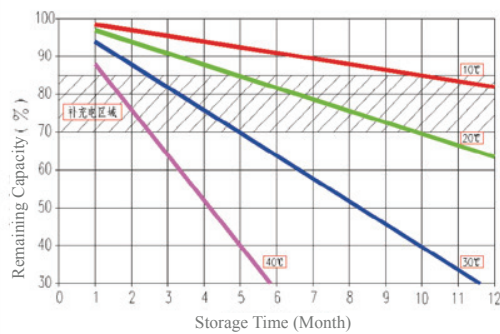

Temperature Effects In Relation To Capacity

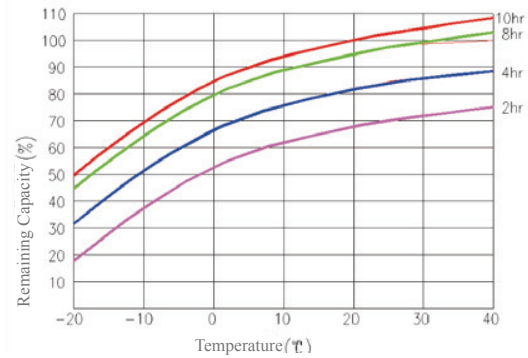

Constant Voltage Charge Characteristics

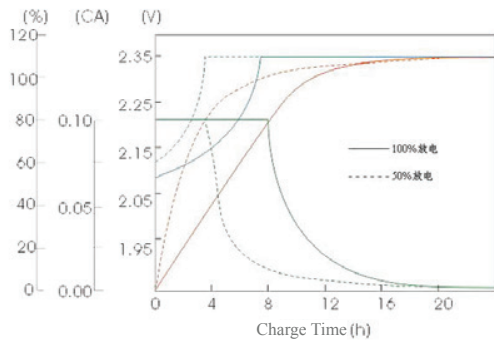

Discharge Characteristics

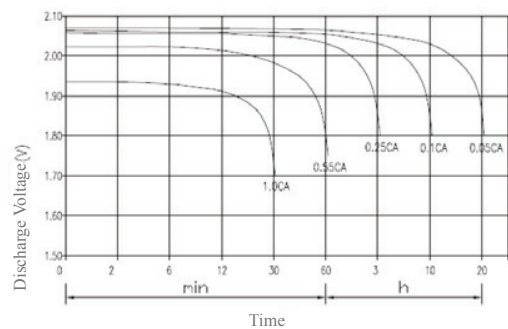

For trade enquiries please contact:

M/s Newstar Investments Limited

Post Box 27-300, Mount Roskill, Auckland 1440, New Zealand | Telephone +649 801 0976 | Email – sales@enlight.co.nz | website: www.enlight.co.nz

EVH High Temperature VRLA Battery Series



Typical Applications

- Telecom system
- Broadcast and TV system
- Alarm lighting system
- UPS system
- Solar & Wind system
- Power system
- Lighthouse Signal system

Features

- Long float charge design life (18 years at 25°C, 10 years at 35 °C)
- Wide operating temperature range, can work between -40 to 80°C
- Pressure and impact resistance structure design
- Strong high temperature resistance container material
- AGM GEL electrolyte technology
- Flat plate technology
- Safe explosion venting system



| Item | Model | Rated Voltage (V) | Rated Capacity (Ah) | | | Dimension | | | Weight (KG) |
|------|------------|---------------------|-----------------------|----------------|----------------|-----------|------|-------|---------------|
| | | | C ₁₀ | C ₃ | C ₁ | L mm | W mm | TH mm | |
| 1 | EVH-200 | 2 | 200 | 150 | 110 | 88 | 177 | 377 | 15.0 |
| 2 | EVH-300 | 2 | 300 | 225 | 165 | 118 | 177 | 377 | 21.0 |
| 3 | EVH-400 | 2 | 400 | 300 | 220 | 148 | 177 | 377 | 27.0 |
| 4 | EVH-500 | 2 | 500 | 375 | 275 | 187 | 177 | 377 | 33.0 |
| 5 | EVH-600 | 2 | 600 | 450 | 330 | 218 | 178 | 377 | 40.0 |
| 6 | EVH-650 | 2 | 650 | 487.5 | 357.5 | 175 | 212 | 455 | 45.0 |
| 7 | EVH-800 | 2 | 800 | 600 | 440 | 212 | 212 | 455 | 56.0 |
| 8 | EVH-1000 | 2 | 1000 | 750 | 550 | 256 | 212 | 455 | 68.0 |
| 9 | EVH-1500 | 2 | 1500 | 1125 | 825 | 275 | 210 | 687 | 106.0 |
| 10 | EVH-2000 | 2 | 2000 | 1500 | 1100 | 367 | 214 | 687 | 144.0 |
| 11 | EVH-3000 | 2 | 3000 | 2250 | 1650 | 542 | 212 | 687 | 210.0 |
| 12 | 6-EVH-100F | 12 | 100 | 75 | 55 | 520 | 107 | 263 | 36.0 |
| 13 | 6-EVH-150F | 12 | 150 | 112.5 | 82.5 | 528 | 125 | 318 | 52.5 |
| 14 | 6-EVH-200F | 12 | 200 | 150 | 110 | 550 | 125 | 330 | 60.0 |
| 15 | 6-EVH-38 | 12 | 38 | 28.5 | 20.9 | 197 | 166 | 168.5 | 13.5 |
| 16 | 6-EVH-65 | 12 | 65 | 48.75 | 35.75 | 324 | 168 | 175 | 21.5 |
| 17 | 6-EVH-100 | 12 | 100 | 75 | 55 | 408 | 175 | 221 | 37.0 |
| 18 | 6-EVH-150 | 12 | 150 | 112.5 | 82.5 | 549 | 204 | 233 | 56.0 |
| 19 | 6-EVH-200 | 12 | 200 | 150 | 110 | 549 | 259 | 233 | 73.0 |

EVH High Temperature VRLA Battery Series



Performance Characteristics

Temperature Effects In Relation To Float Charge Voltage

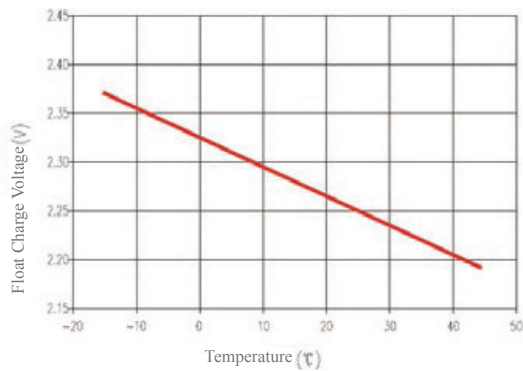

Effect Of Temperature On Float Charge Life

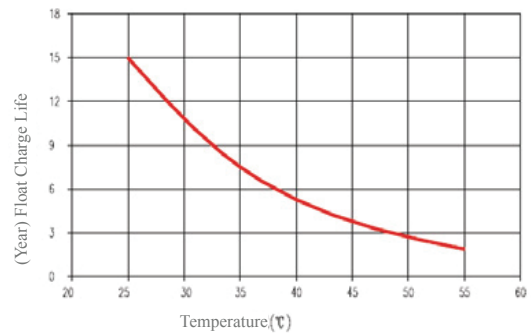

Self Discharge Characteristics

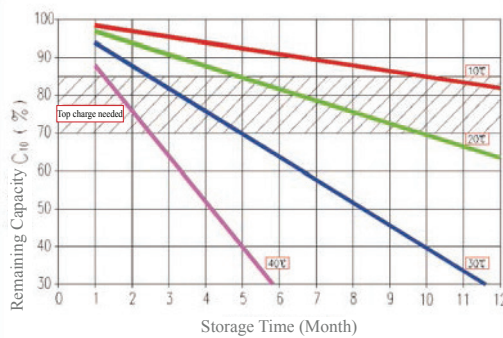

Temperature Effects In Relation To Capacity

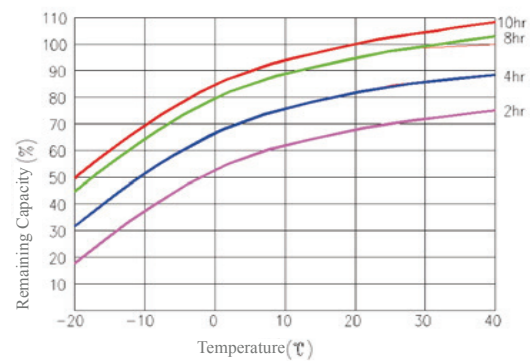

Constant Voltage Charge Characteristics

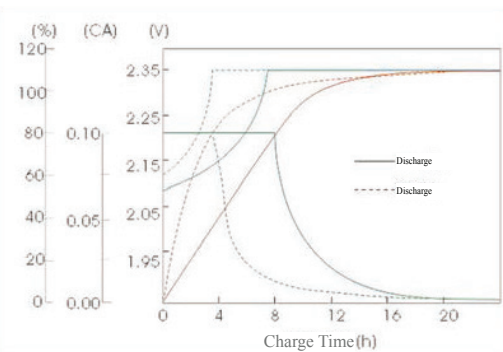

Discharge Characteristics

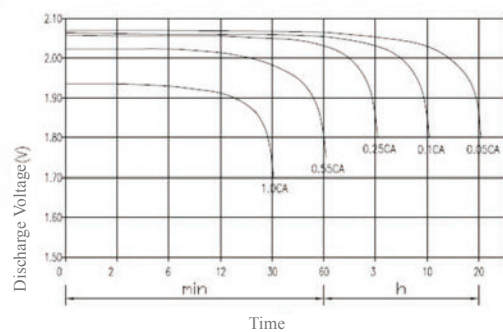

For trade enquiries please contact:

M/s Newstar Investments Limited

Post Box 27-300, Mount Roskill, Auckland 1440, New Zealand | Telephone +649 801 0976 | Email – sales@enlight.co.nz | website: www.enlight.co.nz

EVHR Series For High Rate UPS Application



Typical Applications

- Telecom system
- UPS system
- Power supply system
- Broadcast and television system
- Reserve power system
- Traffic signal system
- Emergency light system

Features

- Float charge design life is 10 years
- Excellent high rate discharge performance
- Good deep discharge recovery performance
- Low self-discharge
- High corrosion resistant alloy with more content of Sn
- Flat plate with special radial pattern technology
- Advanced TTP welding production process
- High strength ABS material case and cover
- AGM sealed valve-regulated
- Advanced TTP welding production process
- Safe and reliable explosion-proof vented system



| Item | Model | Rated Voltage (V) | 15min Rated Power (W@1.67V/cell) | Rated Capacity C ₂₀ (Ah) | Dimension | | | Weight (KG) |
|------|------------|---------------------|------------------------------------|-------------------------------------|-----------|------|-------|---------------|
| | | | | | L mm | W mm | TH mm | |
| 1 | EVHR6V740 | 6 | 740 | 200 | 343 | 174 | 241 | 33.0 |
| 2 | EVHR12V100 | 12 | 100 | 26 | 168 | 131 | 187 | 10.0 |
| 3 | EVHR12V140 | 12 | 140 | 33 | 212 | 131 | 187 | 13.0 |
| 4 | EVHR12V200 | 12 | 200 | 54 | 228 | 139 | 218 | 18.5 |
| 5 | EVHR12V270 | 12 | 270 | 75 | 261 | 174 | 222 | 24.5 |
| 6 | EVHR12V310 | 12 | 310 | 88 | 308 | 174 | 220 | 29.0 |
| 7 | EVHR12V370 | 12 | 370 | 100 | 349 | 174 | 222 | 34.5 |
| 8 | EVHR12V500 | 12 | 500 | 140 | 349 | 174 | 264 | 43.0 |

EVHR Series For High Rate UPS Application



Performance Characteristics

Temperature Effects In Relation To Float Charge Voltage

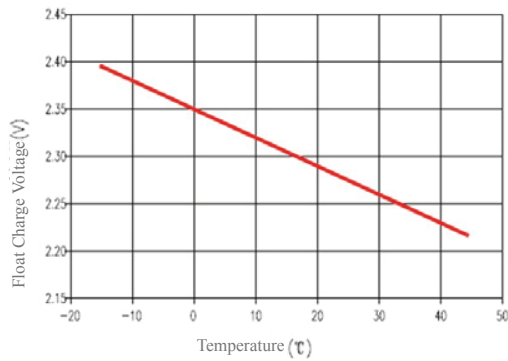

Effect Of Temperature On Float Charge Life

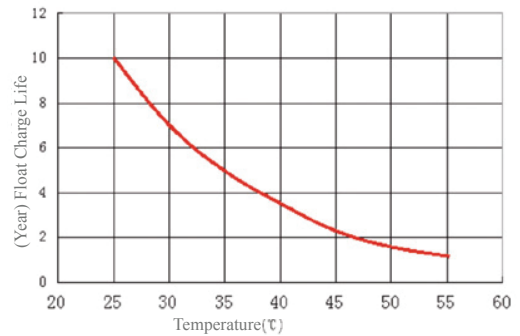

Self Discharge Characteristics

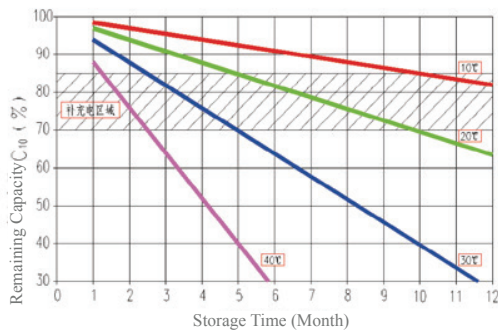

Temperature Effects In Relation To Capacity

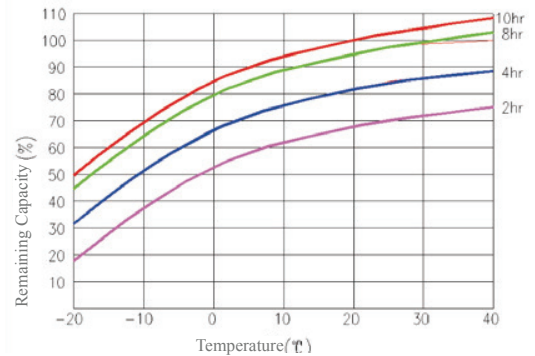

Constant Voltage Charge Characteristics

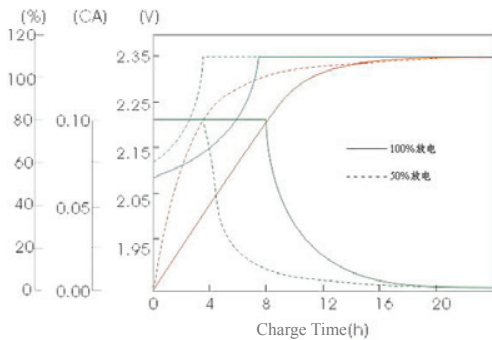

Discharge Characteristics

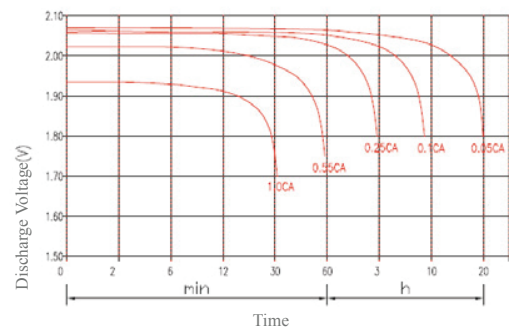

For trade enquiries please contact:

M/s Newstar Investments Limited

Post Box 27-300, Mount Roskill, Auckland 1440, New Zealand | Telephone +649 801 0976 | Email – sales@enlight.co.nz | website: www.enlight.co.nz

EVU Series VRLA Batteries



Typical Applications

- UPS system
- Telecom system
- Power system
- Solar & Wind system
- Broadcast and TV system
- Lighthouse Signal system
- Alarm lighting system
- Data Center

Features

- Float charge design life is 8 years
- Low self discharge
- Perfect deep cycle discharge recovery
- Strong ABS container material
- AGM Valve sealed technology
- Flat plate technology
- Safe explosion venting system



| Item | Model | Rated Voltage (V) | Rated Capacity C ₂₀ (Ah) | Dimension | | | Weight (KG) |
|------|-------------|------------------------|--|-----------|------|-------|------------------|
| | | | | L mm | W mm | TH mm | |
| 1 | 6-EVU-24U | 12 | 24 | 176 | 167 | 125 | 7.2 |
| 2 | 6-EVU-26U | 12 | 26 | 176 | 167 | 125 | 8.0 |
| 3 | 6-EVU-65U | 12 | 65 | 324 | 168 | 175 | 19.0 |
| 4 | 6-EVU-80U | 12 | 80 | 329 | 175 | 221 | 25.5 |
| 5 | 6-EVU-100U | 12 | 100 | 350 | 175 | 220 | 30.5 |
| 6 | 6-EVU-100UI | 12 | 100 | 350 | 175 | 220 | 28.5 |
| 7 | 6-EVU-100Ua | 12 | 100 | 329 | 175 | 221 | 27.5 |
| 8 | 6-EVU-100Ub | 12 | 100 | 329 | 175 | 221 | 29.0 |
| 9 | 6-EVU-100Uc | 12 | 100 | 329 | 175 | 221 | 30.5 |
| 10 | 6-EVU-120U | 12 | 120 | 407 | 177 | 225 | 32.0 |
| 11 | 6-EVU-150U | 12 | 150 | 483 | 170 | 240 | 42.5 |
| 12 | 6-EVU-200U | 12 | 200 | 520 | 239 | 223 | 58.0 |
| 13 | 6-EVU-230U | 12 | 230 | 549 | 259 | 233 | 63.0 |

EVU Series VRLA Batteries



Performance Characteristics

Temperature Effects In Relation To Float Charge Voltage

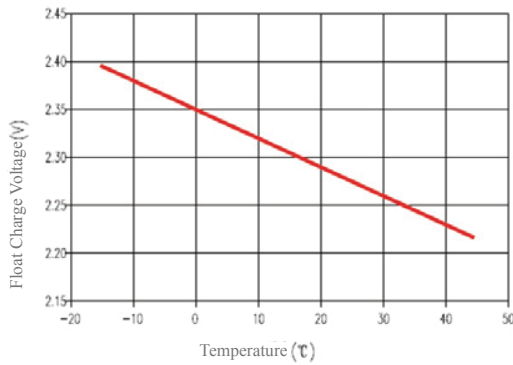

Effect Of Temperature On Float Charge Life

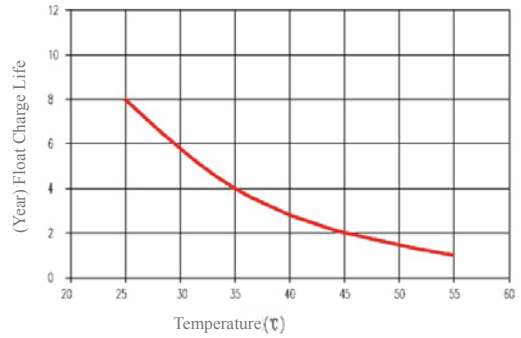

Self Discharge Characteristics

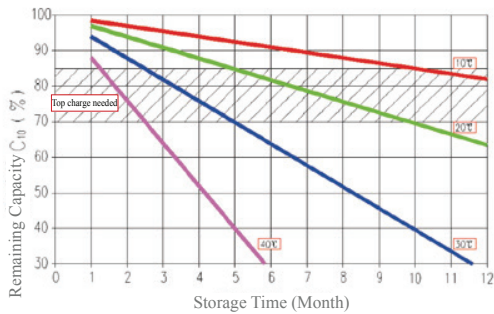

Temperature Effects In Relation To Capacity

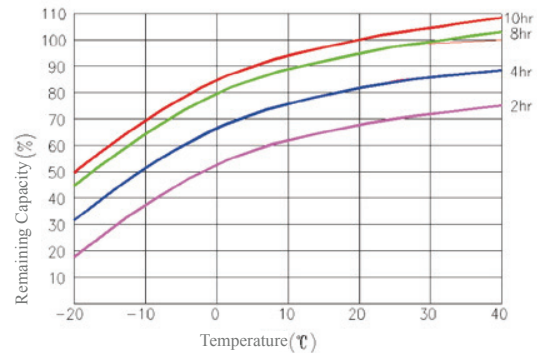

Constant Voltage Charge Characteristics

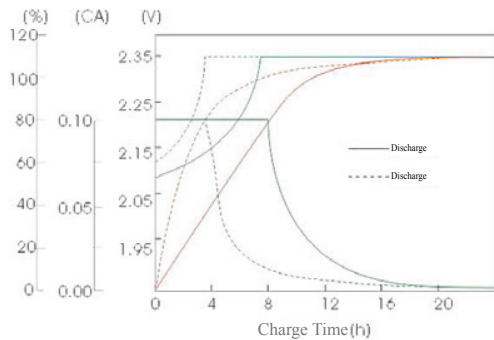

Discharge Characteristics

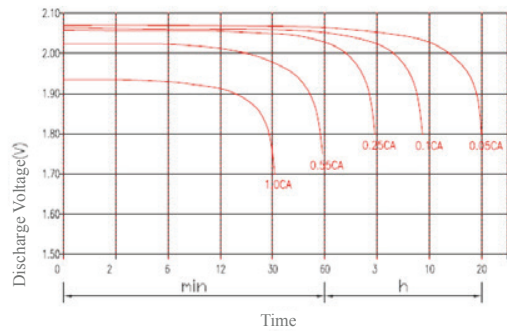

For trade enquiries please contact:

M/s Newstar Investments Limited

Post Box 27-300, Mount Roskill, Auckland 1440, New Zealand | Telephone +649 801 0976 | Email – sales@enlight.co.nz | website: www.enlight.co.nz

EVL Series

Long life VRLA Batteries



Typical Applications

- UPS system
- Telecom system
- Power system
- Broadcast and TV system
- Lighthouse Signal system
- Alarm lighting system

Features

- Float charge design life is 10 years.
- Low self discharge
- Perfect deep cycle discharge recovery
- Use high Tin low Calcium corrosion resisting alloy
- Strong ABS container material
- AGM Valve sealed technology
- Flat plate technology
- Safe explosion venting system



| Item | Model | Rated Voltage (V) | Rated Capacity C ₂₀ (Ah) | Dimension | | | Weight (KG) |
|------|-----------|------------------------|--|-----------|------|-------|------------------|
| | | | | L mm | W mm | TH mm | |
| 1 | 6-EVL-38 | 12 | 38 | 197 | 166 | 168.5 | 13.0 |
| 2 | 6-EVL-65 | 12 | 65 | 324 | 168 | 175 | 21.0 |
| 3 | 6-EVL-100 | 12 | 100 | 408 | 175 | 221 | 32.5 |
| 4 | 6-EVL-120 | 12 | 120 | 408 | 175 | 221 | 35.0 |
| 5 | 6-EVL-150 | 12 | 150 | 549 | 204 | 233 | 49.0 |
| 6 | 6-EVL-200 | 12 | 200 | 549 | 259 | 233 | 63.0 |

EVL Series

Long life VRLA Batteries



Performance Characteristics

Temperature Effects In Relation To Float Charge Voltage

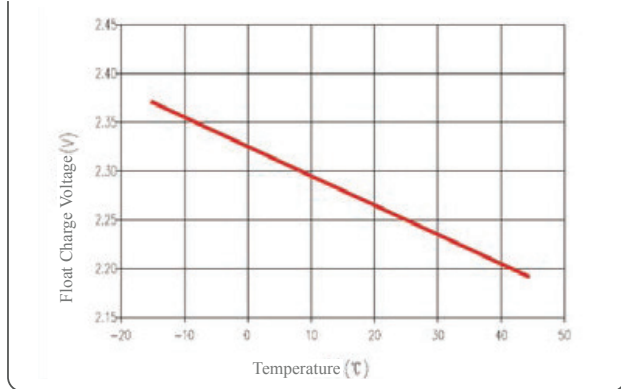

Effect Of Temperature On Float Charge Life

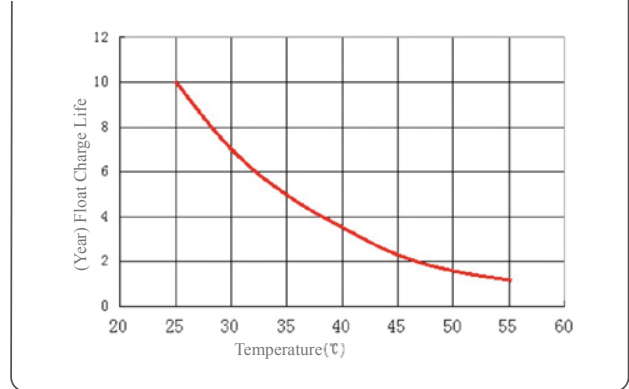

Self Discharge Characteristics

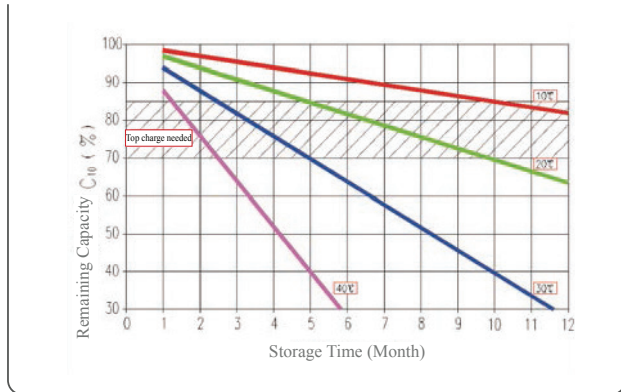

Temperature Effects In Relation To Capacity

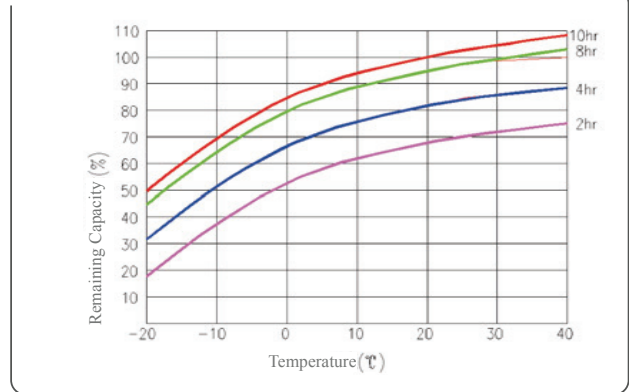

Constant Voltage Charge Characteristics

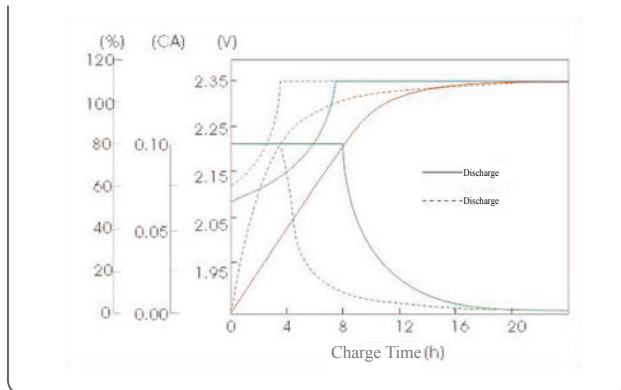

Discharge Characteristics

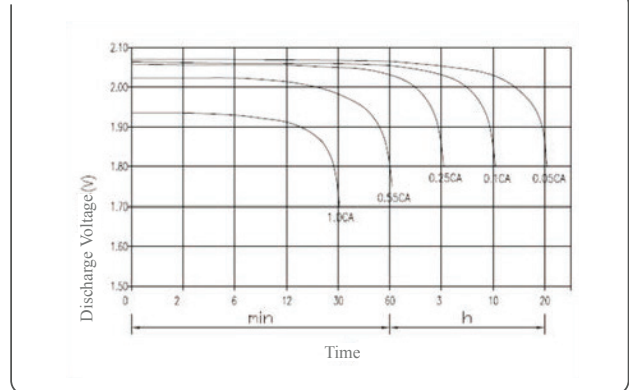

For trade enquiries please contact:

M/s Newstar Investments Limited

Post Box 27-300, Mount Roskill, Auckland 1440, New Zealand | Telephone +649 801 0976 | Email – sales@enlight.co.nz | website: www.enlight.co.nz

EVTG Tubular Gel Battery Series



Typical Applications

- Telecom and signal standby power supply system for Telecom, Mobile, Railway etc.
- Solar & wind energy electric power generation and wind-solar complementary energy storage system.
- Power system, standby power station for nuclear power plant and wind energy power station.
- Marine power supply.
- Petrochemical standby power supply system.

Features

- Float charge design life is 18 years.
- Excellent cycle performance.
- Wide operating temperature range.
- Silica gel electrolyte mixture.
- Adopt tubular positive plates, multi alloy casting grid with good corrosion resistant performance.
- Special PVC-SiO₂ separator with big porosity and low resistance.



| Item | Model | Nominal Voltage (V) | Rated Capacity (Ah) | | | Approx Dimension | | | Approx Weight (KG) |
|------|-----------|-----------------------|-----------------------|----------------|----------------|------------------|------|-------|----------------------|
| | | | C ₁₀ | C ₃ | C ₁ | L mm | W mm | TH mm | |
| 1 | EVTG-200 | 2 | 200 | 150 | 110 | 103 | 206 | 390 | 18.5 |
| 2 | EVTG-300 | 2 | 300 | 225 | 165 | 145 | 206 | 390 | 27.0 |
| 3 | EVTG-400 | 2 | 400 | 300 | 220 | 145 | 206 | 505 | 34.5 |
| 4 | EVTG-500 | 2 | 500 | 375 | 275 | 166 | 206 | 505 | 37.5 |
| 5 | EVTG-600 | 2 | 600 | 450 | 330 | 145 | 206 | 680 | 45.0 |
| 6 | EVTG-800 | 2 | 800 | 600 | 440 | 191 | 210 | 680 | 60.5 |
| 7 | EVTG-1000 | 2 | 1000 | 750 | 550 | 233 | 210 | 680 | 74.5 |
| 8 | EVTG-1200 | 2 | 1200 | 900 | 660 | 275 | 210 | 680 | 88.0 |
| 9 | EVTG-1500 | 2 | 1500 | 1125 | 750 | 275 | 210 | 827 | 117.0 |
| 10 | EVTG-2000 | 2 | 2000 | 1500 | 1000 | 399 | 212 | 802 | 155.0 |
| 11 | EVTG-2500 | 2 | 2500 | 1875 | 1250 | 487 | 212 | 802 | 192.0 |
| 12 | EVTG-3000 | 2 | 3000 | 2250 | 1500 | 576 | 212 | 802 | 228.0 |

EVTG Tubular Gel Battery Series



Performance Characteristics

Temperature Effects In Relation To Float Charge Voltage

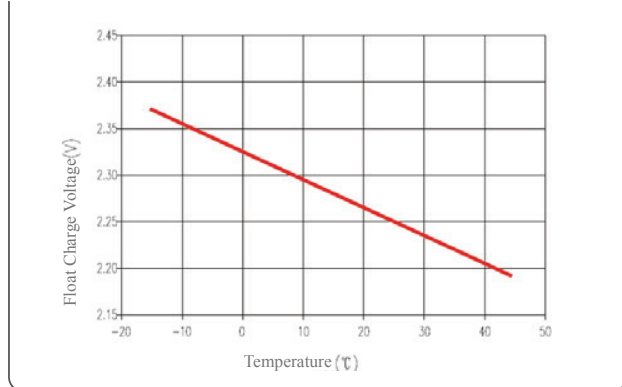

Effect Of Temperature On Float Charge Life

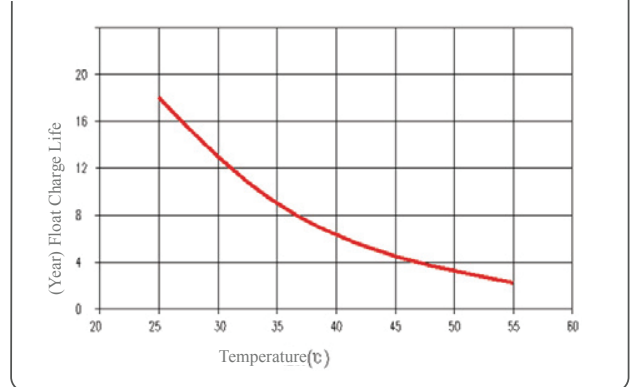

Self Discharge Characteristics

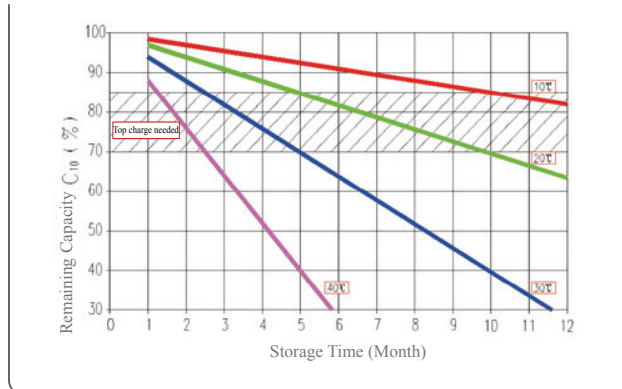

Temperature Effects In Relation To Capacity

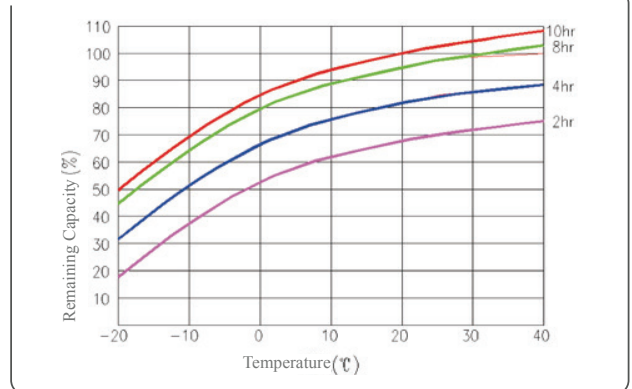

Constant Voltage Charge Characteristics

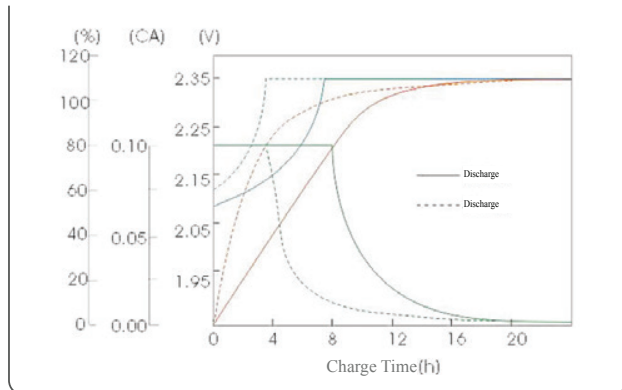

Discharge Characteristics

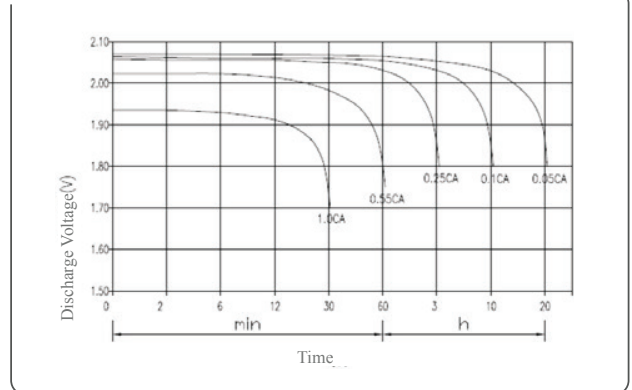

For trade enquiries please contact:

M/s Newstar Investments Limited

Post Box 27-300, Mount Roskill, Auckland 1440, New Zealand | Telephone +649 801 0976 | Email – sales@enlight.co.nz | website: www.enlight.co.nz

EVFP Flat Plate Gel Battery Series



Typical Applications

- Mapping station.
- Roof-mounted PV power system.
- Solar & wind energy power station.
- Photovoltaic water pump system.
- Automatic temperature measurement power supply.
- Remote automation control power supply.
- Outdoor Solar & Wind energy power system.
- Power supply system for frontier sentry and island garrison.
- Solar & wind energy unattended Telecom station.

Features

- Float charge design life is 15 years.
- Excellent cycle performance.
- Special design to reduce the risk of thermal runaway.
- Special PVC-SiO₂ separator with big porosity and low resistance.
- Silica gel electrolyte mixture to eliminate the risk for stratification.
- Flat plate technology.



| Item | Model | Nominal Voltage (V) | Rated Capacity (Ah) | | | Approx Dimension | | | Approx Weight (KG) |
|------|-------------|-----------------------|-----------------------|----------------|----------------|------------------|------|-------|----------------------|
| | | | C ₁₀ | C ₃ | C ₁ | L mm | W mm | TH mm | |
| 1 | 6-EVFP-100 | 12 | 100 | 75 | 55 | 408 | 175 | 221 | 38.5 |
| 2 | 6-EVFP-120 | 12 | 120 | 90 | 66 | 549 | 204 | 233 | 47.5 |
| 3 | 6-EVFP-150 | 12 | 150 | 112.5 | 82.5 | 549 | 204 | 233 | 57.5 |
| 4 | 6-EVFP-200 | 12 | 200 | 150 | 110 | 549 | 259 | 233 | 75.5 |
| 5 | 6-EVFP-90J | 12 | 90 | 67.5 | 49.5 | 395 | 110 | 286 | 33.0 |
| 6 | 6-EVFP-100J | 12 | 100 | 75 | 55 | 520 | 107 | 263 | 36.0 |
| 7 | 6-EVFP-150J | 12 | 150 | 112.5 | 82.5 | 550 | 125 | 310 | 55.0 |

EVFP Flat Plate Gel Battery Series



Performance Characteristics

Temperature Effects In Relation To Float Charge Voltage

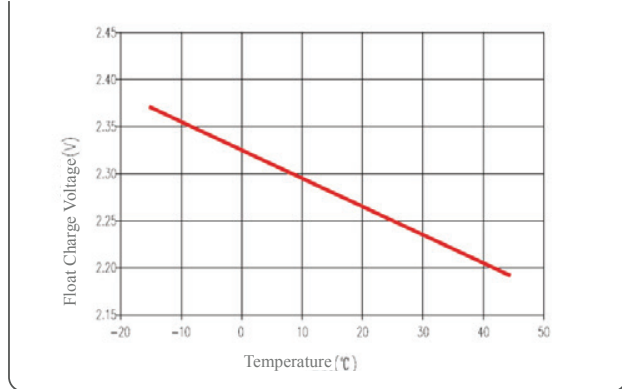

Effect Of Temperature On Float Charge Life

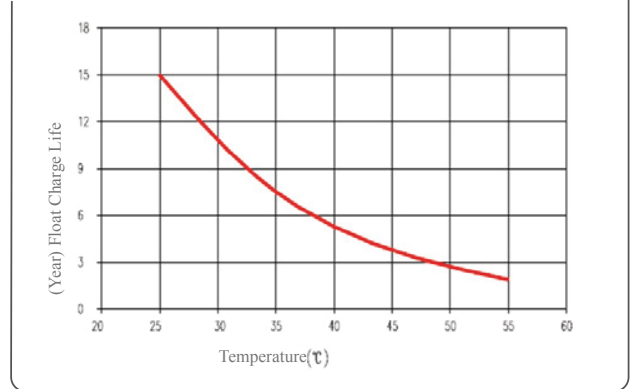

Self Discharge Characteristics

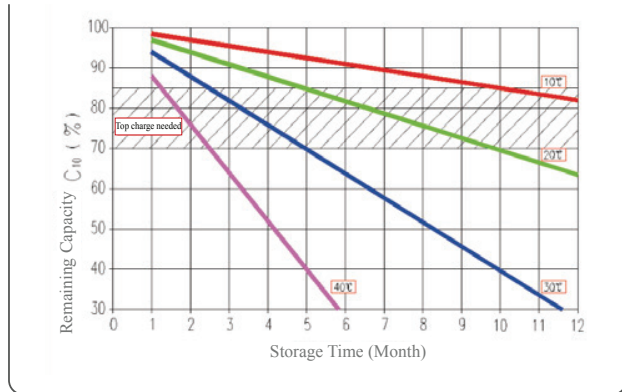

Temperature Effects In Relation To Capacity

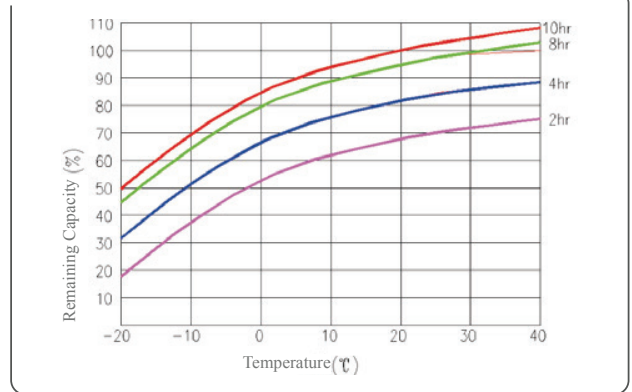

Constant Voltage Charge Characteristics

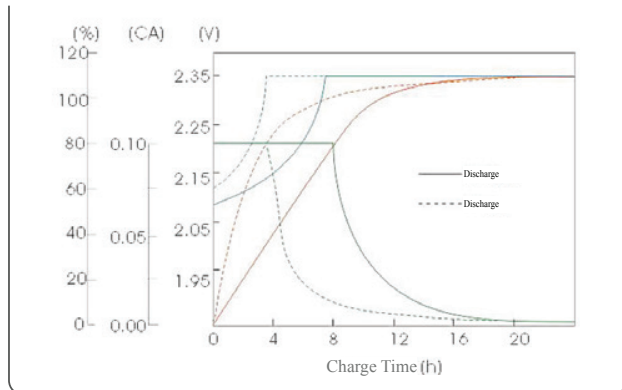

Discharge Characteristics

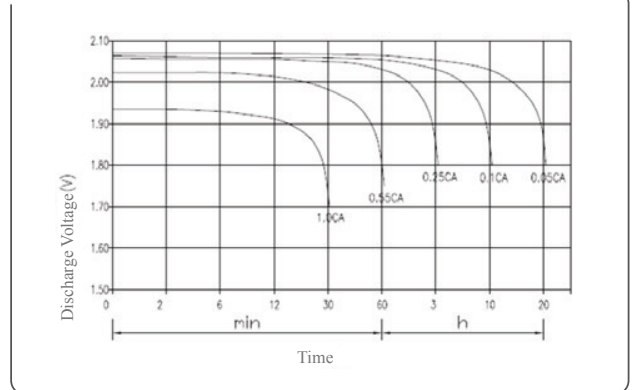

EVFPH Flat Plate Hybrid Gel Battery Series



Typical Applications

- Telecom system.
- Power system.
- Broadcast and television system.
- Beacon signal system.
- Solar & wind power storage station.
- Smart grid and outdoor street lamp system.

Features

- Float charge design life is more than 12 years.
- Cycle performance is 20% higher than normal AGM battery.
- Adding gel into electrolyte helps to slow down electrolyte stratification.
- Multi alloy technology for positive grid.
- Proprietary 4BS plate.



| Item | Model | Nominal Voltage (V) | Rated Capacity (Ah) | | | Approx Dimension | | | Approx Weight (KG) |
|------|----------------|-----------------------|-----------------------|----------------|----------------|------------------|------|-------|----------------------|
| | | | C ₁₀ | C ₃ | C ₁ | L mm | W mm | TH mm | |
| 1 | EVFPH-200J | 2 | 200 | 150 | 110 | 88 | 177 | 377 | 13.0 |
| 2 | EVFPH-300J | 2 | 300 | 225 | 165 | 118 | 177 | 377 | 18.0 |
| 3 | EVFPH-400J | 2 | 400 | 300 | 220 | 148 | 177 | 377 | 23.0 |
| 4 | EVFPH-500J | 2 | 500 | 375 | 275 | 187 | 177 | 377 | 29.0 |
| 5 | EVFPH-600J | 2 | 600 | 450 | 330 | 218 | 178 | 377 | 35.0 |
| 6 | EVFPH-650J | 2 | 650 | 487.5 | 357.5 | 175 | 212 | 455 | 40.0 |
| 7 | EVFPH-800J | 2 | 800 | 600 | 440 | 212 | 212 | 455 | 50.0 |
| | | | | | | 290 | 180 | 378 | 46.0 |
| 8 | EVFPH-1000J | 2 | 1000 | 750 | 550 | 256 | 212 | 455 | 61.0 |
| | | | | | | 368 | 180 | 378 | 57.0 |
| 9 | EVFPH-1500J | 2 | 1500 | 1125 | 825 | 275 | 210 | 687 | 95.0 |
| 10 | EVFPH-2000J | 2 | 2000 | 1500 | 1100 | 367 | 214 | 687 | 129.0 |
| 11 | EVFPH-3000J | 2 | 3000 | 2250 | 1650 | 542 | 212 | 687 | 189.0 |
| 12 | 6-EVFPH-38J | 12 | 38 | 28.5 | 20.9 | 197 | 166 | 168 | 13.2 |
| 13 | 6-EVFPH-50J | 12 | 50 | 37.5 | 27.5 | 270 | 168 | 184 | 17.8 |
| 14 | 6-EVFPH-65J | 12 | 65 | 48.75 | 35.75 | 324 | 168 | 175 | 21.3 |
| 15 | 6-EVFPH-80J | 12 | 80 | 60 | 44 | 329 | 175 | 221 | 25.8 |
| 16 | 6-EVFPH-100J | 12 | 100 | 75 | 55 | 329 | 175 | 221 | 30.8 |
| 17 | 6-EVFPH-120J | 12 | 120 | 90 | 66 | 408 | 175 | 221 | 35.3 |
| 18 | 6-EVFPH-150J | 12 | 150 | 112.5 | 82.5 | 549 | 204 | 233 | 49.0 |
| 19 | 6-EVFPH-200J | 12 | 200 | 150 | 110 | 520 | 239 | 223 | 59.0 |
| 20 | 6-EVFPH-50YJ | 12 | 50 | 37.5 | 27.5 | 390 | 107 | 200 | 18.5 |
| 21 | 6-EVFPH-92YJ | 12 | 92 | 69 | 50.6 | 396 | 111 | 285 | 29.5 |
| 22 | 6-EVFPH-100BYJ | 12 | 100 | 75 | 55 | 396 | 111 | 285 | 31.0 |
| 23 | 6-EVFPH-100AYJ | 12 | 100 | 75 | 55 | 520 | 107 | 263 | 33.0 |
| 24 | 6-EVFPH-120YJ | 12 | 120 | 90 | 66 | 520 | 107 | 263 | 39.5 |
| 25 | 6-EVFPH-150YJ | 12 | 150 | 112.5 | 82.5 | 558 | 125 | 283 | 48.0 |
| 26 | 6-EVFPH-170YJ | 12 | 170 | 127.5 | 93.5 | 528 | 125 | 318 | 53.0 |
| 27 | 6-EVFPH-200YJ | 12 | 200 | 150 | 110 | 550 | 125 | 330 | 62.0 |

EVFPH Flat Plate Hybrid Gel Battery Series



Performance Characteristics

Temperature Effects In Relation To Float Charge Voltage

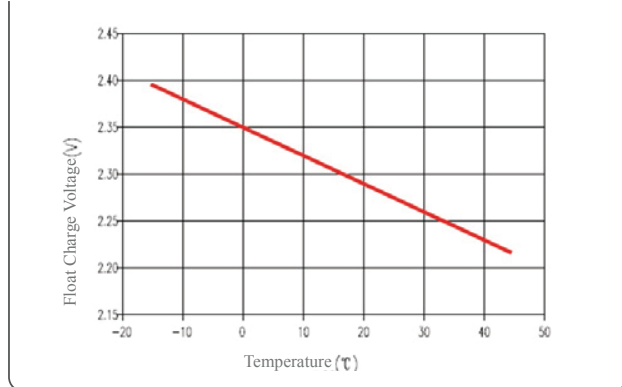

Effect Of Temperature On Float Charge Life

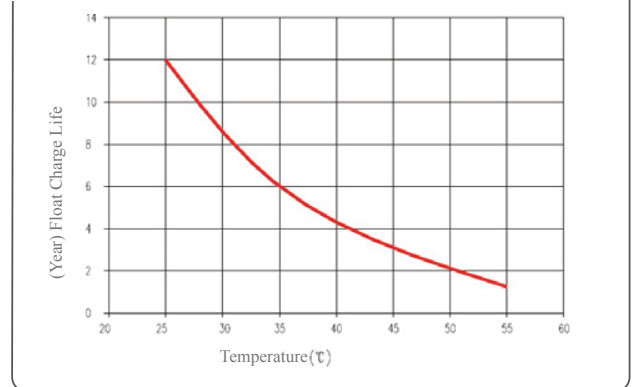

Self Discharge Characteristics

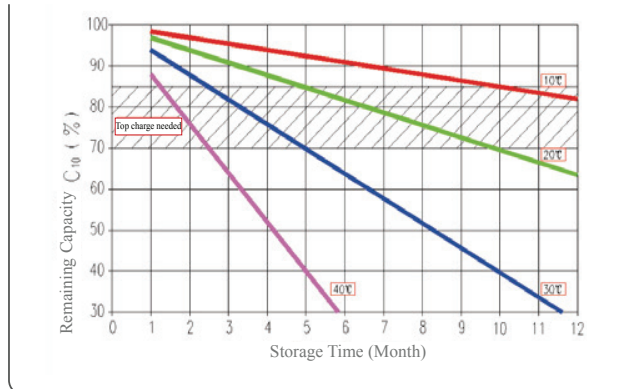

Temperature Effects In Relation To Capacity

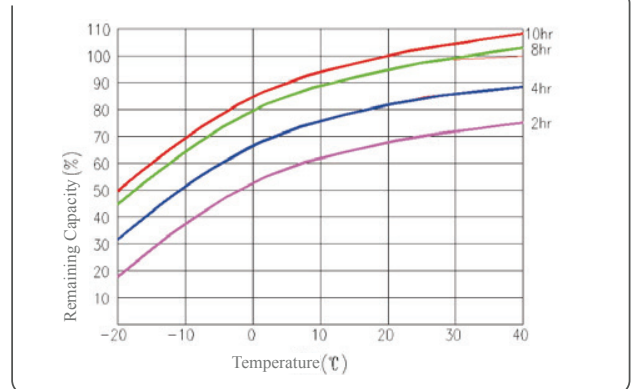

Constant Voltage Charge Characteristics

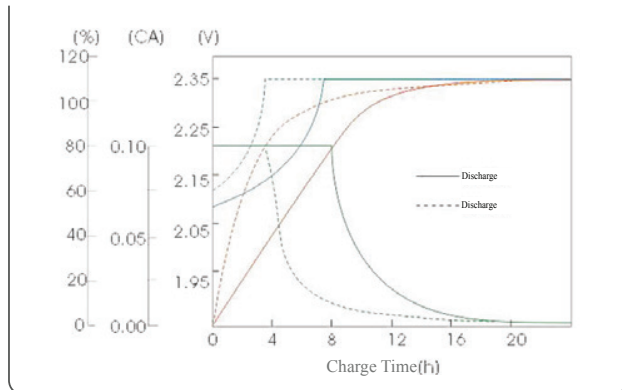

Discharge Characteristics

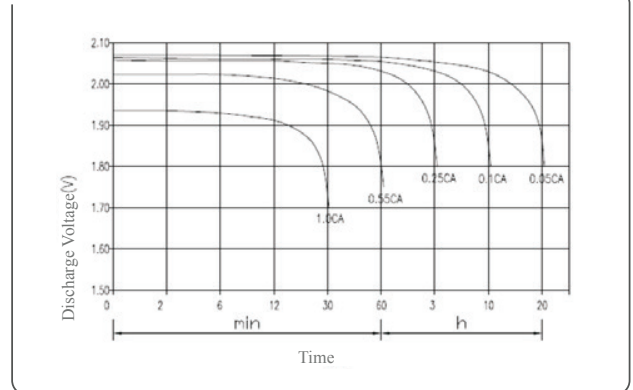

For trade enquiries please contact:

M/s Newstar Investments Limited

Post Box 27-300, Mount Roskill, Auckland 1440, New Zealand | Telephone +649 801 0976 | Email – sales@enlight.co.nz | website: www.enlight.co.nz

LifePO₄ Battery System for Telecom Application



It is the 48V system for Telecommunication standby type LiFePO₄ (lithium iron phosphate) battery products, the system uses the advanced LiFePO₄ battery technology with the benefit of long cycle life, small size, light weight, safety and environmental protection, and has a strong environmental adaptability, it is idea for harsh outdoor environments.

The system also integrates a smart battery management and monitoring module, support for remote centralized monitoring and remote battery management and maintenance, to meet the requirements of unattended. Therefore, the system can fully meet the backup power supply requirements of the access network equipment, mobile communications equipment, transmission equipment, micro base stations and microwave communication equipment.



Features and Benefits

- With the latest development technology trends of international Telecommunication battery, adopt advanced Fe lithium battery system.
- Advanced intelligent lithium battery management technology to ensure the intelligent automatic management.
- With "Energy transfer" balanced patented technology, provide high efficiency balanced and prolong system operate life.
- Excellent electromagnetic compatibility. The outdoor power system with this product comply with the main equipment when they working together, no interfere with each other.
- Complete intelligent design, centralized monitoring unit have function of "three remote" (remote measure, remote communication, remote control), The system managed by computer, communicate with the remote monitoring center, unattended, in line with the requirements of the development of modern communications technology.
- Combine the power control technology and computer technology, real-time monitoring and control the rectifier, AC and DC power distribution.
- Configuration flexibility, support parallel connection expansion.

General Specifications

| Item | Type | Nominal Voltage (V) | Nominal Capacity (Ah) | Charge Voltage (V) | Max. Charge Current (A) | Optional Charging Current limit(A) | Output Voltage (V) | Max. Output Current (A) | Dimensions (WxDxH in mm) | Weight (kg) |
|------|---------------|---------------------|-----------------------|--------------------|-------------------------|------------------------------------|--------------------|-------------------------|--------------------------|-------------|
| 1 | EVL48-10FT01 | 48 | 10 | 54.0 +/- 0.5 | 5 | 2 | 37.5 to 54.7 | 10 | 442x260x44 | 6.5 |
| 2 | EVL48-20FT01 | 48 | 20 | 54.0 +/- 0.5 | 10 | 2 | 37.5 to 54.7 | 10 | 442x400x88 | 12 |
| 3 | EVL48-40FT01 | 48 | 40 | 54.0 +/- 0.5 | 20 | 10 | 37.5 to 54.7 | 40 | 442x400x132 | 22 |
| 4 | EVL48-50FT01 | 48 | 50 | 54.0 +/- 0.5 | 20 | 10 | 37.5 to 54.7 | 50 | 442x400x132 | 30 |
| 5 | EVL48-70FT01 | 48 | 70 | 54.0 +/- 0.5 | 50 | 15 | 37.5 to 54.7 | 50 | 442x400x220 | 40 |
| 6 | EVL48-75FT01 | 48 | 75 | 54.0 +/- 0.5 | 50 | 15 | 37.5 to 54.7 | 50 | 442x400x220 | 45 |
| 7 | EVL48-100FT01 | 48 | 100 | 54.0 +/- 0.5 | 50 | 15 | 37.5 to 54.7 | 50 | 442x400x264 | 60 |

Note: ① Nominal voltage---cell nominal voltage 3.2V, 48V battery consist of 15 cells.

② Nominal capacity---discharge with constant current (0.2CA) to end voltage (37.5V) at 25°C.

③ The batteries can be customized.

LifePO₄ Battery System for Telecom Application



Battery system panel



- 1 Input and output (DC)
- 2 Cascading communication (RS-485)
- 3 Up-link communication (RS-232)
- 4 Address dial number (ADD)
- 5 Alarm (red) and run (green) LED light
- 6 Indicator light for capacity (SOC)

Performance Curve

Charge and discharge performance of single cell

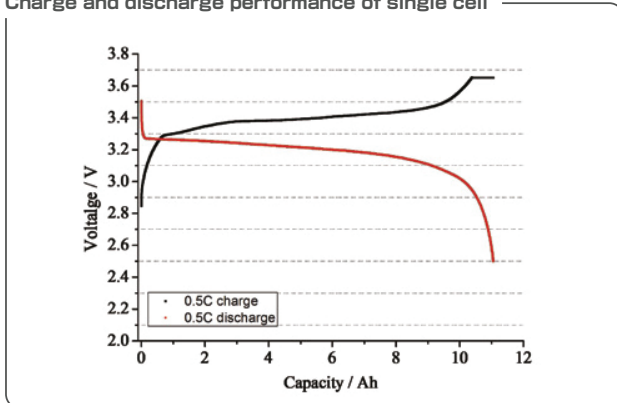

Discharge performance at different discharge rate of single cell

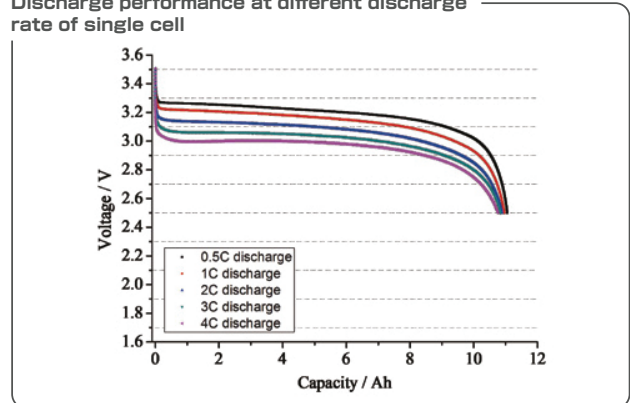

Constant Voltage Charge Characteristics

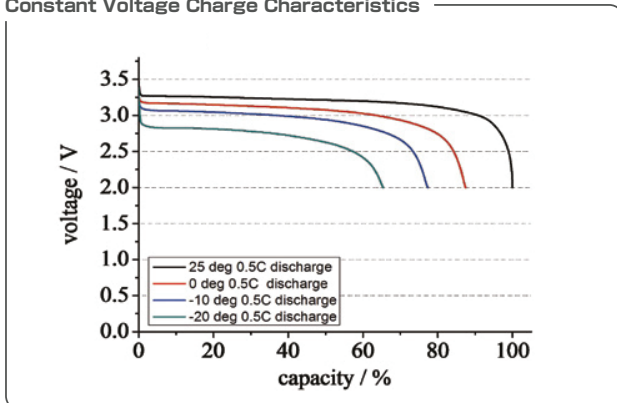

Discharge Characteristics

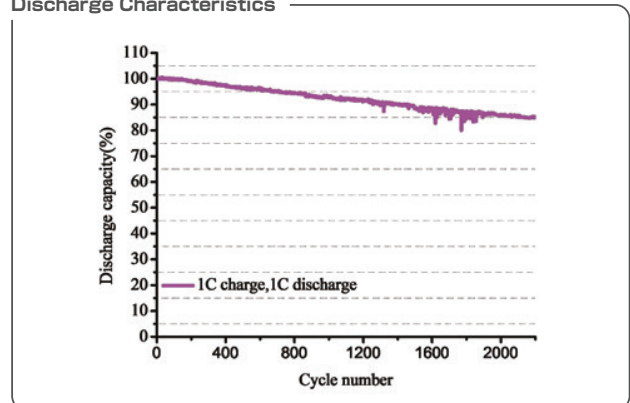

Operation Environment

- Working temperature: -10°C ~ +55°C.
- Storage temperature: -20°C ~ +45°C.
- Relative humidity : 25% ~ 85%, no condensation.
- Altitude : 0~2000m, if altitude above 2000m, the max working temperature decrease 1°C every 200m. Max. altitude is 4000m.

For trade enquiries please contact:

M/s Newstar Investments Limited

Post Box 27-300, Mount Roskill, Auckland 1440, New Zealand | Telephone +649 801 0976 | Email – sales@enlight.co.nz | website: www.enlight.co.nz

LifePO₄ Battery System for Energy Storage



Typical Applications

- Distributed PV power station
- Off grid energy storage system
- Solar street lamp
- Wind and PV energy storage
- Roof solar energy storage
- Microgrid energy storage system

Features

- High energy density, small Size, light weight. Ultra long cycle performance.
- Reliability: high safe and reliable system hardware configuration. Soft packed LiFePO₄ battery cell and modular design.
- Safety: Perfect protect system: overvoltage protection, short circuit protection, overheat protection, overload protection, etc.. Comply with EN61000-6-1, EN61000-6-2, EN61000-6-3, EN61000-6-4, EN61000-3-2, EN61000-3-3, EN60164-1-1, EN55022, EN50178, etc..
- High usability: easy to be installed and have CAN, RS485 port.
- Expansibility: RS485 port is reserved, easy to connect computer and read monitor data.



| Item | Model | Nominal Voltage (V) | Rated Capacity C ₂₀ (Ah) | Approx Dimension | | | Approx Weight (KG) |
|------|-------------|-----------------------|-------------------------------------|------------------|------|-------|----------------------|
| | | | | L mm | W mm | TH mm | |
| 1 | EVLE220-120 | 220 | 20 | 800 | 600 | 2200 | 360 |
| 2 | EVLE600-40 | 600 | 40 | 800 | 600 | 2200 | 360 |
| 3 | EVLE600-80 | 600 | 80 | 800 | 1000 | 2200 | 720 |
| 4 | EVLE336-40 | 336 | 40 | 800 | 600 | 2200 | 185 |
| 5 | EVLE12-10 | 12 | 10 | 170 | 100 | 65 | 1.5 |
| 6 | EVLE12-20 | 12 | 20 | 170 | 100 | 120 | 3 |
| 7 | EVLE12-40 | 12 | 40 | 170 | 200 | 120 | 6 |
| 8 | EVLE24-10 | 24 | 10 | 170 | 100 | 120 | 3 |
| 9 | EVLE24-20 | 24 | 20 | 170 | 200 | 120 | 6 |
| 10 | EVLE24-40 | 24 | 40 | 240 | 200 | 170 | 12 |

Note: The batteries can be customized.

LifePO₄ Battery System for Energy Storage



System Operation Panel



- 1 Input and Output (DC)
- 2 RS-485 cascade communication
- 3 RS232 mainframe monitor communication
- 4 Address code (ADD)
- 5 LED light of alarm (red) and running (green)
- 6 Indicator light of SOC

Performance Characteristics

Charge and discharge characteristics curve

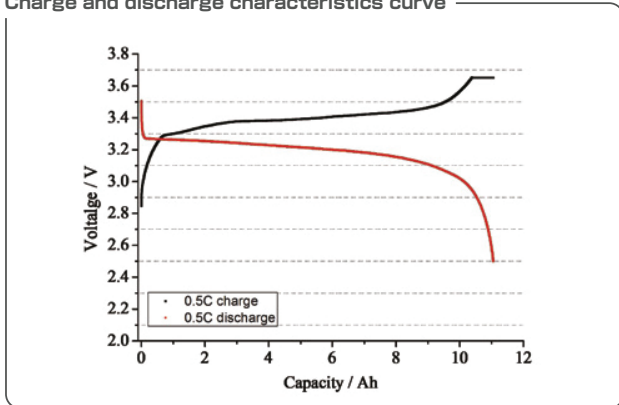

Discharge characteristics

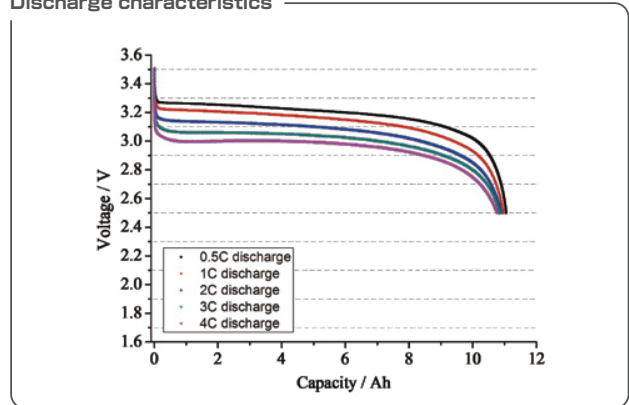

Temperature effects on capacity

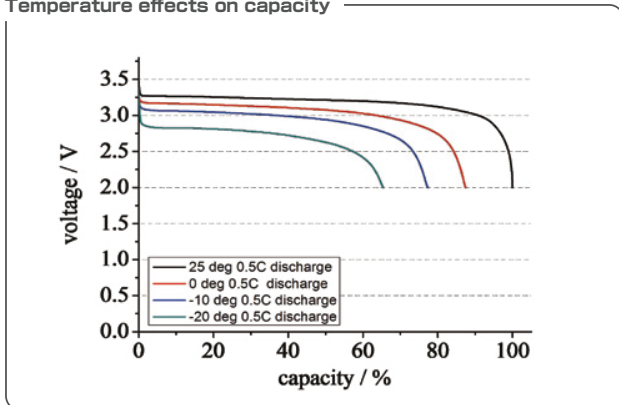

Cycle performance characteristics Curve

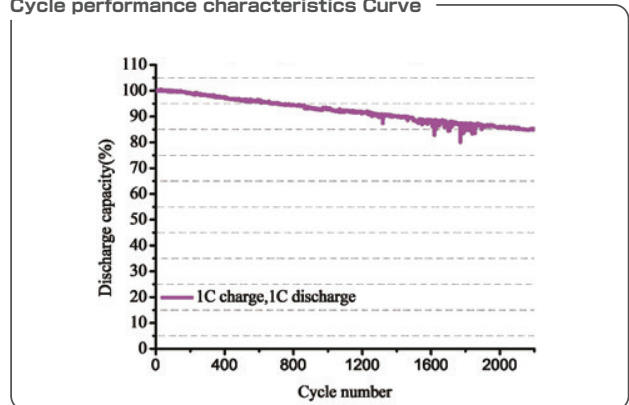

Work Environment

- Operation Temperature : -10°C ~ +55°C.
- Storage Temperature : -20°C ~ +45°C.
- Relative Humidity : 25% ~ 85%.
- Altitude : 0~2000m, If it is high than 2000 meters, the maximum operating temperature will be reduced by 1 degree Celsius every 200 meters. The allowed maximum altitude is 4000 meters.

For trade enquiries please contact:

M/s Newstar Investments Limited

Post Box 27-300, Mount Roskill, Auckland 1440, New Zealand | Telephone +649 801 0976 | Email – sales@enlight.co.nz | website: www.enlight.co.nz

LifePO₄ Battery System for Power Application



Typical Applications

- Electric motorcycle, low speed electric vehicles
- Golf cart, patrol car
- Tourism boat and Patrol car
- Intelligent warehouse motive system

Features

- High energy density, small size, light weight, excellent safety and reliable performance. Ultra long cycle performance, environment friendly energy.
- 3 CAN communication modes, keeping the real-time communication with the vehicle control unit, car charger and LCD.
- Battery balance technology. Solving the battery consistency problem through active and passive balance technology, and this technology can be customized.
- Increase the capacity by parallel connection
- SOC self learning technology.
Calculating battery capacity through real time data collection and automatically adjust the SOC data.
- Heating film management(Optional)
In low temperature, heating film will be started and heat the surface of the battery, to ensure the performance of battery capacity.
- Alarm function
Beside the basic protection alarm function, BMS can also send the information of power off, low voltage etc. to the monitoring system.
- LCD display function
LCD (Optional) can display the voltage, temperature, SOC of the battery and alarm, protection information, etc.
- Other functions
Sending alarm, precharge, data storage, indication of battery capacity and running status
- Total solution system is available.



| Item | Model | Rated Voltage (V) | Rated Capacity (Ah) | Dimension | | | Weight (KG) |
|------|---------------|---------------------|-----------------------|-----------|-----|-----|---------------|
| | | | | L | W | TH | |
| 1 | EVL48-10-AL | 48 | 10 | 390 | 150 | 68 | 5.5 |
| 2 | EVL36-10-AL | 36 | 10 | 110 | 75 | 385 | 4.5 |
| 3 | EVL24-10 | 24 | 10 | 87 | 87 | 380 | 2.5 |
| 4 | EVL24-8 | 24 | 8 | 87 | 87 | 380 | 2 |
| 5 | EVL48-10 | 48 | 10 | 130 | 180 | 238 | 6 |
| 6 | EVL48-20 | 48 | 20 | 130 | 180 | 373 | 11 |
| 7 | EVL24-60 | 24 | 60 | 330 | 310 | 120 | 18 |
| 8 | EVL48-40 | 48 | 40 | 420 | 178 | 195 | 19.5 |
| 9 | EVL48-120FM01 | 48 | 120 | 500 | 500 | 230 | 55 |

Note: The batteries can be customized.

LifePO₄ Battery System for Power Application



Performance Characteristics

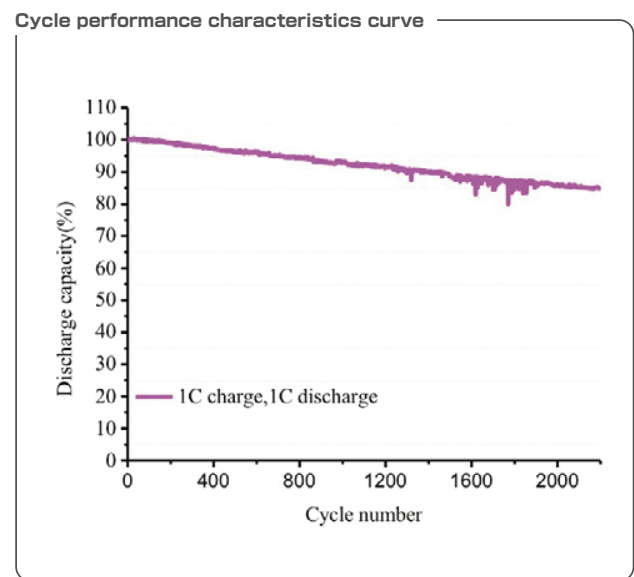
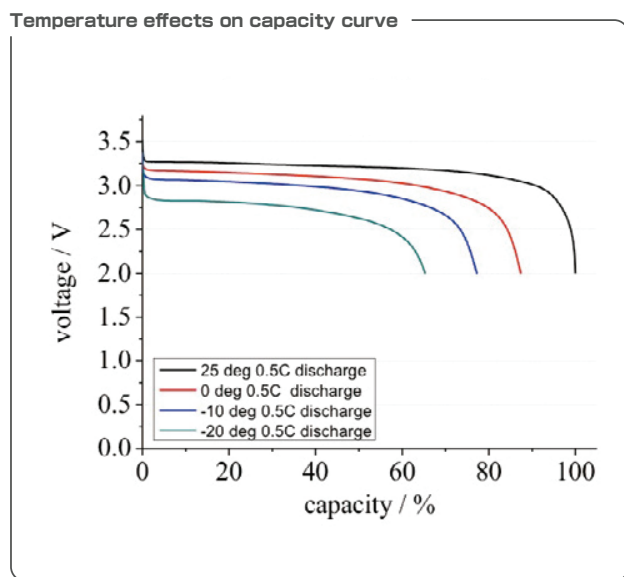
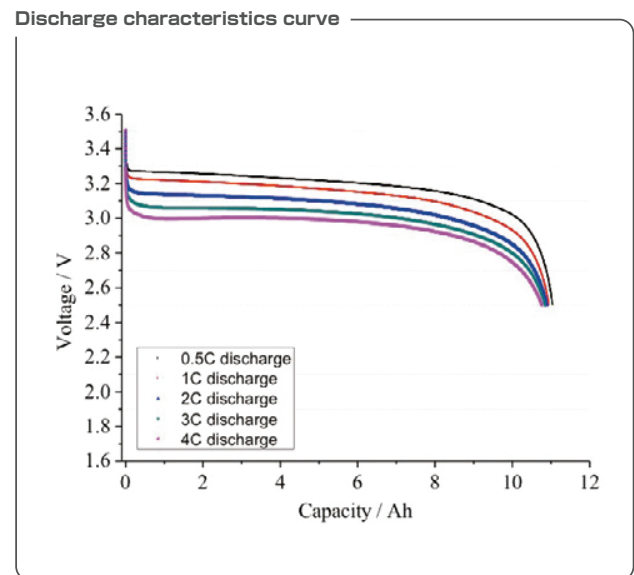
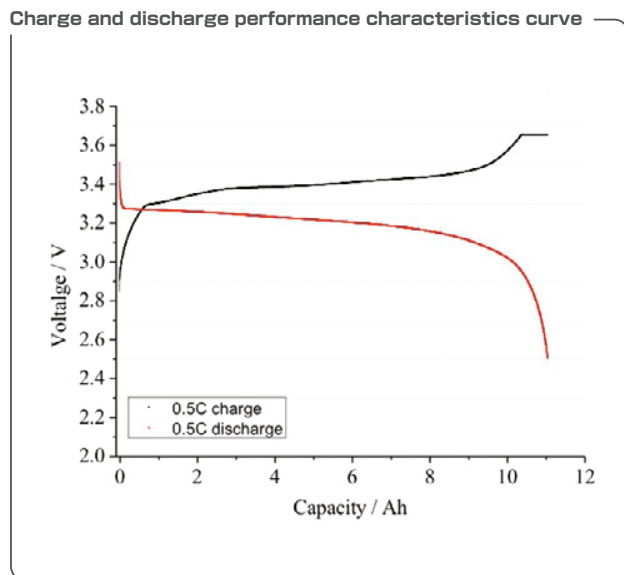

Work Environment

- Charge : 0°C ~ 45°C
- Discharge : -10°C ~ 55°C
- 30 Days Storage : -20°C ~ 45°C
- 90 Days Storage : -20°C ~ 35°C

For trade enquiries please contact:
M/s Newstar Investments Limited

Post Box 27-300, Mount Roskill, Auckland 1440, New Zealand | Telephone +649 801 0976 | Email – sales@enlight.co.nz | website: www.enlight.co.nz

EVF Series

Motive Battery



Typical Applications

- Electric car, electric bus, hybrid electric vehicles
- Golf cart, electric patrol car, tourism car, boat
- Electric van, electric forklift, electric fork truck
- Electric scooters
- Electric cleaning vehicles

Features

- Large capacity and high energy density.
- Long cycle life. Good performance in low temperature.
- Rapid charging performance and good deep discharge recovery performance.
- Special sealed structure to avoid leakage.
- Maintenance free , low self-discharge and little water loss.
- Special copper core structure and excellent high current discharge performance.
- Gel electrolyte, no acid fog escape. Green energy.



| Item | Model | Rated Voltage (V) | Rated Capacity 3hr (Ah) | Dimension (± 3mm) | | | | Weight (KG) | Hour Rate Discharge | | | |
|------|------------|---------------------|---------------------------|---------------------|-----|-----|-----|---------------|---------------------|---------------|-------------|---------------|
| | | | | L | W | H | TH | | 3hr | | 5hr | |
| | | | | | | | | | Current (A) | Capacity (Ah) | Current (A) | Capacity (Ah) |
| 1 | 3-EVF-150 | 6 | 150 | 260 | 180 | 247 | 252 | 30 | 50 | 150 | 32 | 160 |
| 2 | 3-EVF-180 | 6 | 180 | 260 | 180 | 272 | 274 | 35 | 60 | 180 | 38.4 | 192 |
| 3 | 3-EVF-200 | 6 | 200 | 260 | 180 | 272 | 274 | 36.5 | 67 | 200 | 44 | 220 |
| 4 | 3-EVF-200S | 6 | 200 | 330 | 180 | 220 | 222 | 36.5 | 67 | 200 | 44 | 220 |
| 5 | 3-EVF-210 | 6 | 210 | 260 | 180 | 272 | 274 | 37 | 70 | 210 | 46.2 | 231 |
| 6 | 3-EVF-260 | 6 | 260 | 356 | 180 | 272 | 278 | 46 | 86.7 | 260 | 57.2 | 286 |
| 7 | 4-EVF-150 | 8 | 150 | 260 | 180 | 280 | 280 | 37 | 50 | 150 | 32 | 160 |
| 8 | 4-EVF-135 | 8 | 135 | 260 | 180 | 280 | 280 | 35.5 | 45 | 135 | 28.4 | 142 |
| 9 | 6-EVF-40 | 12 | 40 | 196 | 165 | 175 | 175 | 16 | 13.3 | 40 | 8.6 | 43 |
| 10 | 6-EVF-60 | 12 | 60 | 260 | 169 | 215 | 215 | 24 | 20 | 60 | 12.8 | 64 |
| 11 | 6-EVF-65 | 12 | 65 | 260 | 169 | 215 | 215 | 25 | 21.7 | 65 | 14 | 70 |
| 12 | 6-EVF-80 | 12 | 80 | 260 | 169 | 215 | 215 | 26.5 | 26.7 | 80 | 17 | 85 |
| 13 | 6-EVF-85 | 12 | 85 | 260 | 169 | 215 | 215 | 27 | 28.3 | 85 | 18.2 | 91 |
| 14 | 6-EVF-100 | 12 | 100 | 330 | 171 | 214 | 216 | 35.5 | 33 | 100 | 21.2 | 106 |
| 15 | 6-EVF-120 | 12 | 120 | 407 | 171 | 240 | 240 | 41 | 40 | 120 | 25.6 | 128 |
| 16 | 6-EVF-135 | 12 | 135 | 341 | 172 | 281 | 283 | 46 | 45 | 135 | 28.4 | 142 |
| 17 | 6-EVF150 | 12 | 150 | 482 | 170 | 240 | 240 | 52 | 50 | 150 | 32 | 160 |
| 18 | 6-EVF-200 | 12 | 200 | 522 | 239 | 223 | 223 | 70 | 67 | 200 | 44 | 220 |

EVF Series Motive Battery



Performance Characteristics

Discharge characteristics

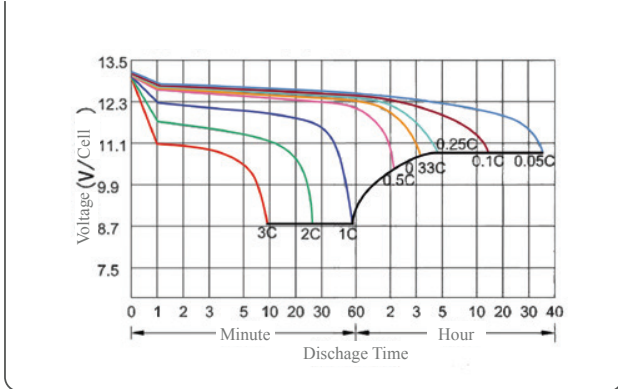

-20°C low temperature characteristics

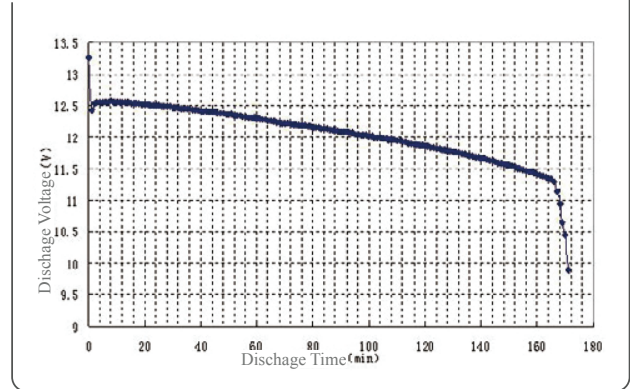

Cycle life characteristics at different DOD

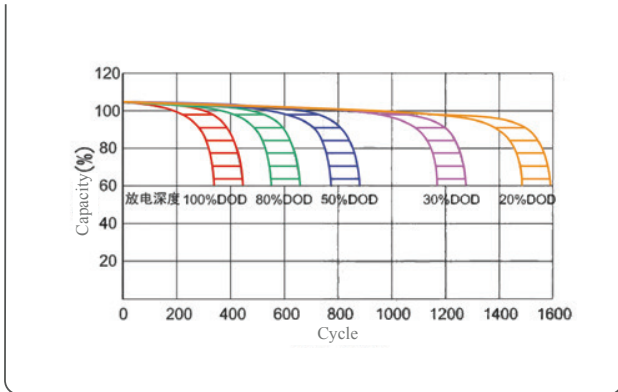

3hr rated capacity characteristics

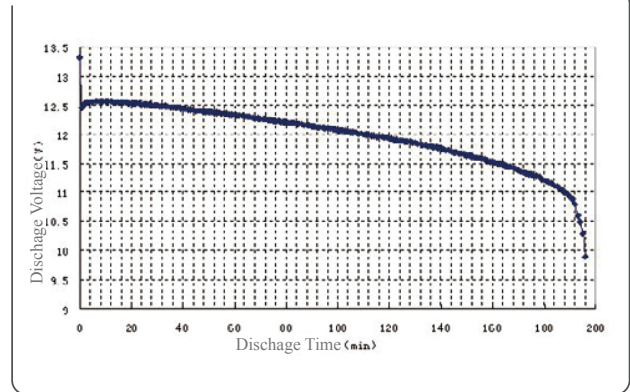

Charge characteristics

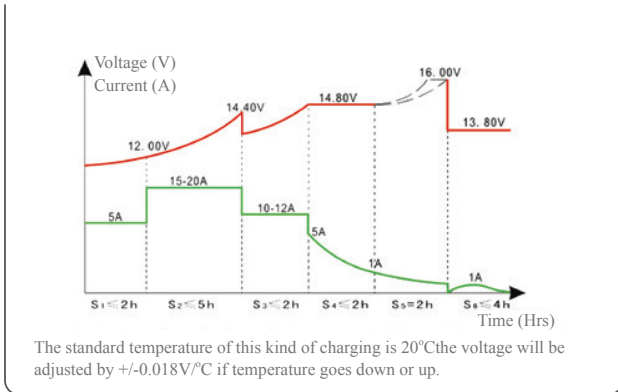

Rapid charging Curve

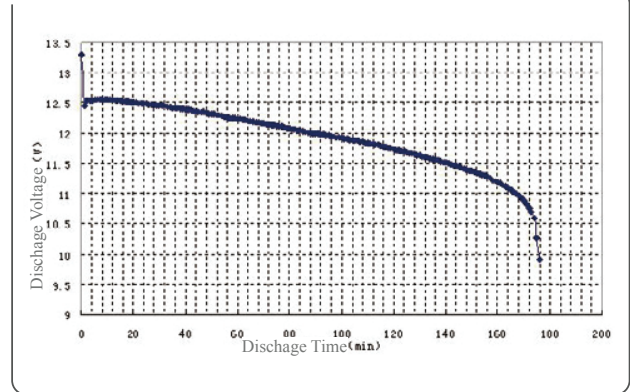

For trade enquiries please contact:

M/s Newstar Investments Limited

Post Box 27-300, Mount Roskill, Auckland 1440, New Zealand | Telephone +649 801 0976 | Email – sales@enlight.co.nz | website: www.enlight.co.nz

QA Series

Dry Charged SLI Battery



Typical Applications

- Various kinds of cars
- Agricultural vehicles
- Medium bus and minibus
- Medium truck and heavy truck
- Roof solar energy storage
- Forklift and boat

Features

- Excellent charge performance, battery can be used after adding the electrolyte.
- Excellent low antimony and lead alloy and little water loss, low self discharge and plate with good anti-corrosion performance to ensure long life.
- Flat plate with special radial pattern technology to reduce internal resistance and ensure good high current start performance.
- Premium PE separator, small pore size, high porosity, low internal resistance and good corrosion resistance performance.
- Particular active material to ensure excellent low temperature start performance.



| Item | Model | Rated Voltage (V) | Rated Capacity | | CCA (A) | Dimension (± 3mm) | | | | Terminal Structure | Terminal Position | Weight (± 0.5KG) |
|------|-----------------|-------------------|----------------------|----------|---------|--------------------|-----|-----|-----|--------------------|-------------------|--------------------|
| | | | C ₂₀ (Ah) | RC (min) | | L | W | H | TH | | | |
| 1 | 6-QA-60(500) | 12 | 60 | 100 | 500 | 260 | 172 | 201 | 221 | 1/4 | 0/1 | 11.5 |
| 2 | 6-QA-80(550) | 12 | 80 | 140 | 550 | 306 | 173 | 203 | 228 | 1/4 | 0/1 | 13.5 |
| 3 | 6-QA-100(650) | 12 | 100 | 182 | 650 | 397 | 173 | 206 | 228 | 1/4 | 0/1 | 17 |
| 4 | 6-QA-105(700) | 12 | 105 | 192 | 700 | 406 | 172 | 215 | 235 | 1/4 | 0/1 | 17 |
| 5 | 6-QA-120(700) | 12 | 120 | 224 | 700 | 510 | 188 | 196 | 220 | 1/4 | 3/4 | 21.5 |
| 6 | 6-QA-135(800) | 12 | 135 | 258 | 800 | 510 | 188 | 196 | 220 | 1/4 | 3/4 | 23 |
| 7 | 6-QA-150(800) | 12 | 150 | 292 | 800 | 508 | 220 | 195 | 230 | 1/4 | 3/4 | 25 |
| 8 | 6-QA-165(850) | 12 | 165 | 326 | 850 | 508 | 220 | 195 | 230 | 1/4 | 3/4 | 27 |
| 9 | 6-QA-180(900) | 12 | 180 | 361 | 900 | 508 | 220 | 195 | 230 | 1/4 | 3/4 | 28 |
| 10 | 6-QA-200(1000) | 12 | 200 | 409 | 1000 | 516 | 270 | 214 | 252 | 4 | 3/4 | 32 |
| 11 | 6-CQA-200(1000) | 12 | 200 | 409 | 1000 | 513 | 262 | 214 | 258 | 4 | 3/4 | 34 |
| 12 | 6-CQA-210(1000) | 12 | 210 | 433 | 1000 | 513 | 262 | 214 | 258 | 4 | 3/4 | 39 |

QA Series

Dry Charged SLI Battery



Adaptable Vehicles

| S.No. | Model | Cars |
|-------|-----------------|--|
| 1 | 6-QA-60(500) | minibus, Medium bus, Medium truck, Van... |
| 2 | 6-QA-80(550) | light truck, minibus (Benz , BMW, Audi, Volvo)... |
| 3 | 6-QA-100(650) | Iveco, Medium bus, Medium truck... |
| 4 | 6-QA-105(700) | |
| 5 | 6-QA-120(700) | Heavy truck, Heavy bus... |
| 6 | 6-QA-135(800) | |
| 7 | 6-QA-150(800) | Heavy bus... |
| 8 | 6-QA-165(850) | |
| 9 | 6-QA-180(900) | Volvo, Benz, Heavy truck... |
| 10 | 6-QA-200(1000) | Volvo, Benz, Heavy truck, Tractor, Boat... |
| 11 | 6-CQA-200(1000) | Boat... |
| 12 | 6-CQA-210(1000) | |

Terminal Structure and Position

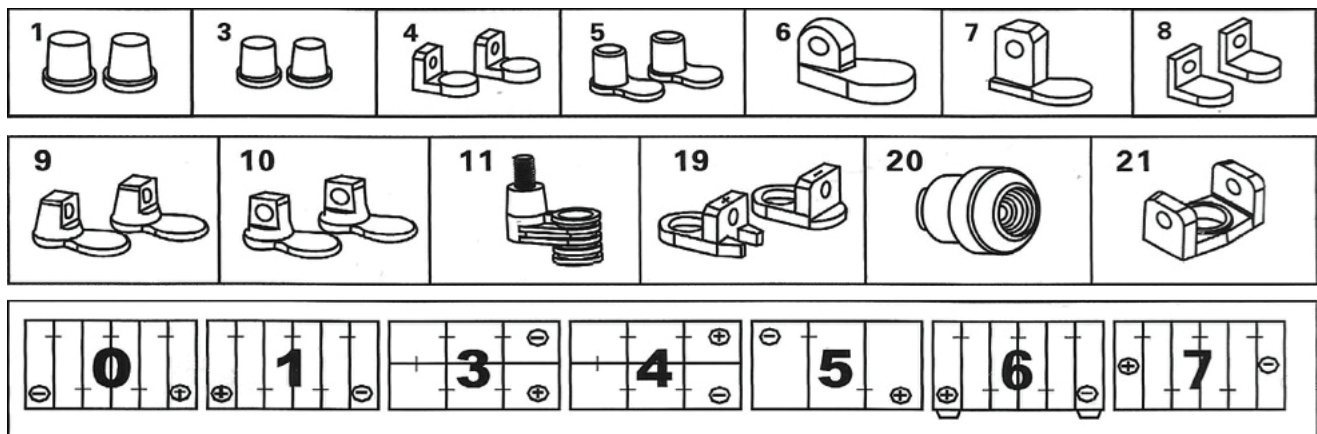

For trade enquiries please contact:

M/s Newstar Investments Limited

Post Box 27-300, Mount Roskill, Auckland 1440, New Zealand | Telephone +649 801 0976 | Email – sales@enlight.co.nz | website: www.enlight.co.nz

Maintenance Free SLI Battery

Typical Applications

- Various kinds of cars
- Agricultural vehicles
- Medium bus and minibus
- Medium truck and heavy truck
- Forklift and boat

Features

- Specially excellent lead calcium and tin alloy and excellent discharge performance, low self discharge and maintenance free.
- Flat plate with special radial pattern technology to reduce internal resistance and ensure good start performance.
- Advanced manufacturing technology, special lead paste to ensure excellent high and low temperature resistance performance and charging receptivity.
- Premium PE separator, small pore size, high porosity, low internal resistance and good corrosion resistance performance.
- Complicated maze structure of battery cover to reduce water loss. Good breathability, anti acid fog escape and anti explosion.
- Electro-hydraulic display to show the capacity accurately. Easy to see the conditions of the battery



| Item | Model | Rated Voltage (V) | Rated Capacity | | CCA (A) | Dimension (± 3mm) | | | | Terminal Structure | Terminal Position | Weight (± 0.5KG) |
|------|----------------|-------------------|----------------------|----------|---------|-------------------|-----|-----|-----|--------------------|-------------------|------------------|
| | | | C ₂₀ (Ah) | RC (min) | | L | W | H | TH | | | |
| 1 | 6-QW-36(280) | 12 | 36 | 53 | 280 | 197 | 128 | 200 | 220 | 3 | 1 | 10.5 |
| 2 | 6-QW-45(350) | 12 | 45 | 75 | 350 | 242 | 128 | 200 | 220 | 1/3 | 1 | 12.5 |
| 3 | 6-QW-54(500) | 12 | 54 | 88 | 500 | 289 | 175 | 175 | 175 | 1 | 0 | 17 |
| 4 | 75D23MF(500) | 12 | 60 | 100 | 500 | 225 | 172 | 202 | 223 | 1 | 0 | 16.5 |
| 5 | 6-QW-60(500) | 12 | 60 | 100 | 500 | 260 | 175 | 200 | 220 | 1/4 | 0 | 17.5 |
| 6 | 6-QW-75(550) | 12 | 75 | 130 | 550 | 260 | 175 | 200 | 220 | 1/4 | 0/1 | 20 |
| 7 | 6-QW-80(550) | 12 | 80 | 140 | 550 | 306 | 175 | 205 | 225 | 1/4 | 0 | 20.5 |
| 8 | 6-QW-90(600) | 12 | 90 | 160 | 600 | 306 | 175 | 205 | 225 | 1/4 | 0 | 22 |
| 9 | 6-QW-100(650) | 12 | 100 | 182 | 650 | 405 | 175 | 208 | 230 | 1/4 | 1 | 25.5 |
| 10 | 6-QW-120(700) | 12 | 120 | 224 | 700 | 405 | 175 | 208 | 230 | 1/4 | 1 | 29.5 |
| 11 | 6-QW-120T(700) | 12 | 120 | 224 | 700 | 510 | 180 | 195 | 220 | 1/4 | 4 | 32.5 |
| 12 | 6-QW-135(800) | 12 | 135 | 258 | 800 | 510 | 180 | 195 | 220 | 1/4 | 4 | 34 |
| 13 | 6-QW-150(800) | 12 | 150 | 292 | 800 | 505 | 220 | 212 | 235 | 1/4 | 4 | 39 |
| 14 | 6-QW-165(850) | 12 | 165 | 326 | 850 | 505 | 220 | 212 | 235 | 1/4 | 4 | 40 |
| 15 | 6-QW-180(900) | 12 | 180 | 361 | 900 | 505 | 220 | 212 | 235 | 1/4 | 4 | 41 |
| 16 | 6-QW-200(1000) | 12 | 200 | 409 | 1000 | 517 | 266 | 220 | 240 | 1/4 | 4 | 51 |
| 17 | 6-QW-210(1000) | 12 | 210 | 433 | 1000 | 517 | 266 | 220 | 240 | 1/4 | 4 | 53 |

QW Series

Maintenance Free SLI Battery



Adaptable Vehicles

| S.No. | Model | Cars |
|-------|----------------|---|
| 1 | 6-QW-36(280) | Suzuki, Alto... |
| 2 | 6-QW-45(350) | Geely Series, Chery... |
| 3 | 6-QW-54(500) | Santana, Jetta, Audi, Chery, Lexus... |
| 4 | 75D23MF(500) | Chery, Honda Accord, Toyota Crown... |
| 5 | 6-QW-60(500) | Southeast, |
| 6 | 6-QW-75(550) | Hyundai, Honda Accord, Audi, Passat, Pickup, Minibus, Van... |
| 7 | 6-QW-80(550) | Honda, Nissan, Isuzu, Passat, Lexus 300/400, Toyota Crown, Chery... |
| 8 | 6-QW-90(600) | |
| 9 | 6-QW-100(650) | Medium Bus, Medium Truck, Tricycle, Tractor... |
| 10 | 6-QW-120(700) | Medium Bus, Medium Truck... |
| 11 | 6-QW-120T(700) | Heavy truck, Heavy bus... |
| 12 | 6-QW-135(800) | |
| 13 | 6-QW-150(800) | Heavy bus... |
| 14 | 6-QW-165(850) | |
| 15 | 6-QW-180(900) | Volvo, Benz, Heavy truck... |
| 16 | 6-QW-200(1000) | Volvo, Benz, Heavy truck, Tractor, Boat... |
| 17 | 6-QW-210(1000) | |

Terminal Structure and Position

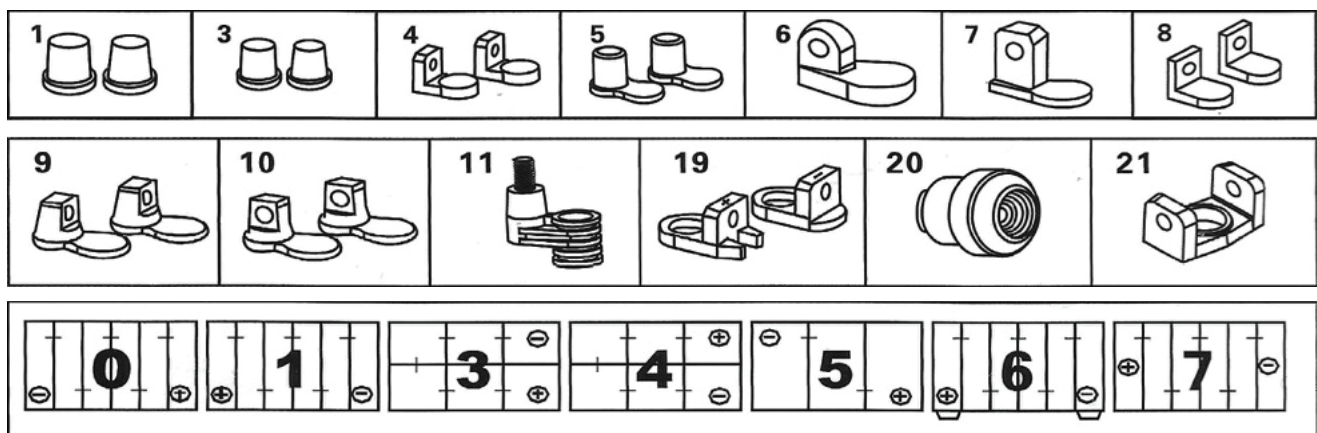

For trade enquiries please contact:

M/s Newstar Investments Limited

Post Box 27-300, Mount Roskill, Auckland 1440, New Zealand | Telephone +649 801 0976 | Email – sales@enlight.co.nz | website: www.enlight.co.nz

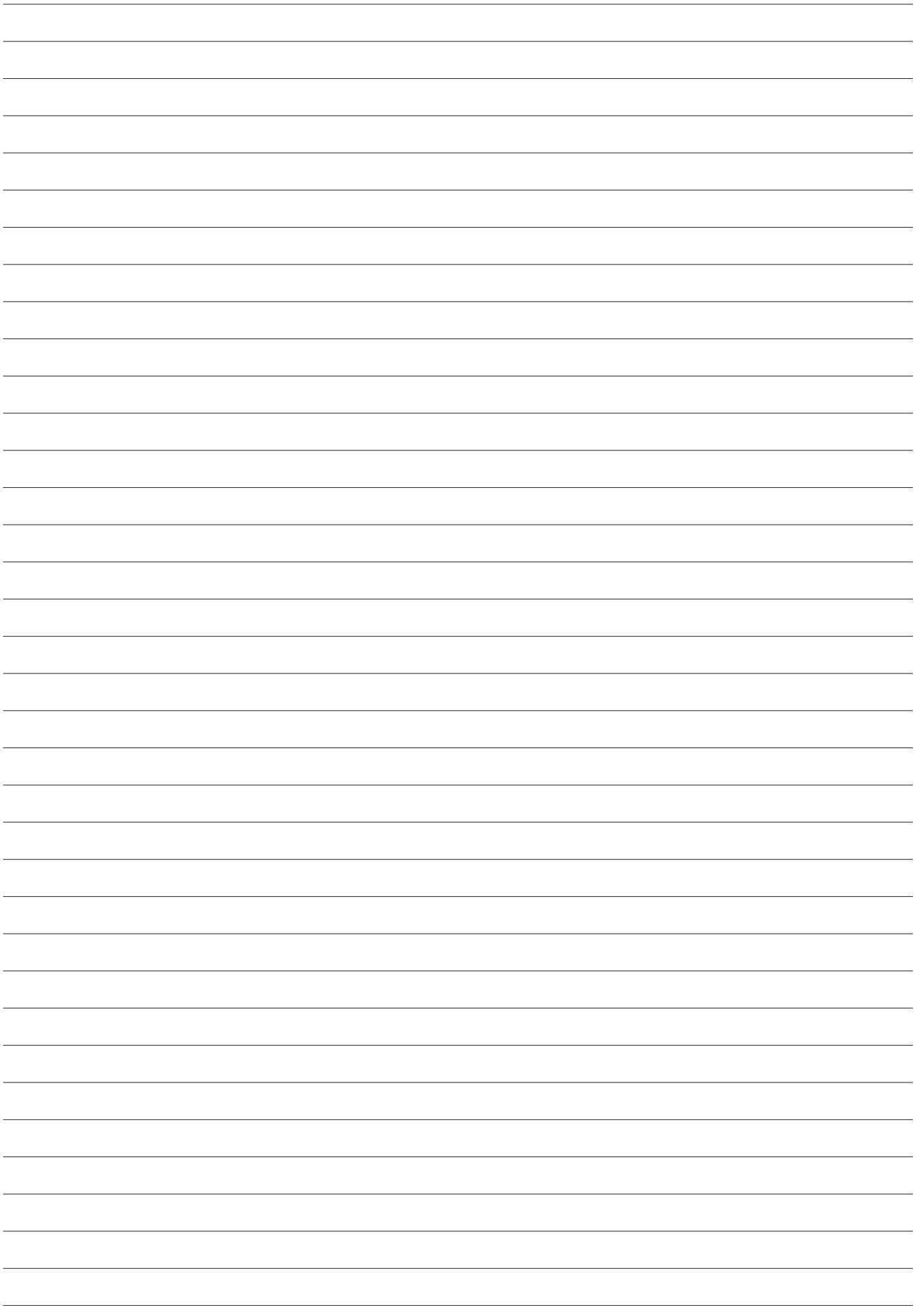



Enlight is a registered trade mark of M/s Newstar Investments Limited

For trade enquiries please contact:
M/s Newstar Investments Limited
Post Box 27-300, Mount Roskill, Auckland 1440, New Zealand
Telephone +649 801 0976 | Email – sales@enlight.co.nz | website: www.enlight.co.nz